

2017-0210

**INTRODUCED BY: LARRY COCHRAN, PARISH PRESIDENT
(DEPARTMENT OF PUBLIC WORKS)**

ORDINANCE NO. 17-7-5

An ordinance to approve Amendment No. 2 to Easement No. DACW29-2-95-08, the Department of the Army Permit for the Engineers Canal Pump Station, to authorize the installation of an additional 20,000 gpm stormwater pump in Engineers Canal, Norco.

WHEREAS, the St. Charles Parish Council adopted Ordinance No. 95-9-14 on September 18, 1995 approving Department of Army Easement No. DACW29-2-95-08 for the Engineers Canal Pump Station located at 688 West Pine Street in Norco; and,

WHEREAS, the St. Charles Parish Council adopted Ordinance No. 05-6-11 on June 20, 2005, approving Amendment No. 1 to the Department of Army Easement No. DACW29-2-95-08 for the Engineers Canal Pump Station, to authorize the installation of a bypass culvert; and,

WHEREAS, the Department of Public Works has proposed to install, operate and maintain an additional 20,000 gpm stormwater pump in the existing concrete sump, a 26" diameter at-grade steel pipeline 286 LF across the Bonnet Carre' Spillway lower guide levee on an existing, but thickened slab, a laydown area, work area of 20' x 286', and access for construction within St. Charles Parish, Louisiana; and,

WHEREAS, the Department of Army Corps of Engineers has prepared Amendment No. 2 to the original Easement agreement to allow said culvert installation; and,

WHEREAS, it is the desire of the Parish Council to approve said Amendment No. 2.

THE ST. CHARLES PARISH COUNCIL HEREBY ORDAINS:

SECTION I. That Amendment No. 2 to Easement No. DACW29-2-95-08 is hereby approved and accepted.

SECTION II. That the Parish President is hereby authorized to execute said Amendment on behalf of St. Charles Parish.

The foregoing ordinance having been submitted to a vote, the vote thereon was as follows:

YEAS: HOGAN, WILSON, CLULEE, GIBBS, BELLOCK, FISHER-PERRIER

NAYS: NONE

ABSENT: BENEDETTO, WOODRUFF, FLETCHER

And the ordinance was declared adopted this 10th day of July, 2017, to become effective five (5) days after publication in the Official Journal.

2017-0210 Easement Engineers Canal Pump Station

CHAIRMAN: Terrill D. Wilson
SECRETARY: [Signature]
DLVD/PARISH PRESIDENT: [Signature]
APPROVED: _____ DISAPPROVED: _____
PARISH PRESIDENT: [Signature]
RETD/SECRETARY: [Signature]
AT: [Signature] RECD BY: [Signature]

RECORDED IN THE ST. CHARLES PARISH
CLERK OF COURT OFFICE
ON August 2, 2017
AS ENTRY NO. 425894
IN MORTGAGE/CONVEYANCE BOOK
NO. 850 FOLIO 788



**AMENDMENT NO. 2
TO
EASEMENT NO. DACW29-2-95-08**

WHEREAS, on 29 August 1995, Easement No. DACW29-2-95-08 was entered between the United States Government, as Grantor, and St. Charles Parish Council, as Grantee, granting a 30 year term, beginning January 1, 1995, and ending December 31, 2024 to construct, use, maintain, control, operate and repair a stormwater pump station along Engineers Canal, including two 26" pipelines across the Bonnet Carre' Spillway lower guide levee at approximate levee station 69+84, and a discharge swale inside the spillway, within our Bonnet Carre' Spillway Project, in Section 5, Township 12 South, Range 8 East, St. Charles Parish, Louisiana;

WHEREAS on 15 July 2005, Amendment No. 1 continued the easement until December 31, 2024 and amended to improve drainage with a 60" corrugated metal bypass culvert to help move water through Engineers Canal past the pump station, under Airline Highway (U.S. Highway 61), ongoing into Bayou Trepagnier pump station on the north side of Highway 61.

NOW THEREFORE, Page 1, first paragraph, is amended to install, operate and maintain an additional 20,000 gpm stormwater pump in the existing concrete sump and 26" diameter at-grade steel pipeline across 286 LF of the Bonnet Carre' Spillway Lower Guide Levee on an existing but thickened slab; additionally, authority is granted for laydown area, work area and access over an of 20' x 286' as shown in Exhibits A & B attached and made part of this instrument, located in an existing right-of-way in the Bonnet Carre' Spillway, in St. Charles Parish, Louisiana.

It has been determined this contract is not subject to Executive Order 13658 or the regulations issued by the Secretary of Labor in 29 CFR part 10 pursuant to the Executive Order, and the following provisions.

If a duly authorized representative of the United States discovers or determines, whether before or subsequent to executing this contract, that an erroneous determination regarding the applicability of Executive Order 13658 was made, contractor, to the extent permitted by law, agrees to indemnify and hold harmless the United States, its officers, agents, and employees, for and from any and all liabilities, losses, claims, expenses, suits, fines, penalties, judgments, demands or actions, costs, fees, and damages directly or indirectly arising out of, caused by, related to, resulting from or in any way predicated upon, in whole or in part, the erroneous Executive Order 13658 determination. This includes contractor releasing any claim or entitlement it would otherwise have to an equitable adjustment to the contract and indemnifying and holding harmless the United States from the claims of subcontractors and contractor employees.

All other terms and conditions of the original easement remain unchanged.

IN WITNESS WHEREOF I have hereunto set my hand by authority/direction of the Secretary of the Army this 28 day of July, 2017.

Mark Hamilton
Witness

MARK HAMILTON
Printed Name

[Signature]
Witness

MARGARET A.D. SEXTON
Printed Name

Judith Y. Gutierrez
JUDITH Y. GUTIERREZ
Real Estate Contracting Officer
Deputy Chief, New Orleans Real Estate
Chief, Management and Disposal Section
Real Estate Region South Division

Marco Rosamano
NOTARY PUBLIC (Sign)

Marco Rosamano
NOTARY PUBLIC (Print)

STATE OF Louisiana

COUNTY OF Orleans

MY COMMISSION EXPIRES: at death

The above Amendment No. 2 is hereby accepted this 20th day of July 2017.

ST. CHARLES PARISH COUNCIL.
Signed: [Signature]
Printed Name: Larry Cochran
Title: Parish President

WITNESSES:

Signed: [Signature]
Printed Name: Dawn H. Higdon

Signed: [Signature]
Printed Name: SARA FOS

Signed: [Signature]
Printed Name: Robert L. Raymond
Notary Public
County/Parish: St. Charles
State Of: Louisiana
My Commission Expires: at death
Notary or Bar Association Number: 15331

BONNET CARRE SPILLWAY PROJECT
SECTION 5/ T12S/ R8E
EASEMENT NO. DACW29-2-95-08
EXHIBIT A

490 24 9045, 30 0 90

ST CHARLES

12S 8E





EVANS-GRAVES ENGINEERS, INC.
ENGINEERING CONSULTANTS ONE GALLERIA BLVD. Ste 1520, METAIRIE, LA. 70001 (504) 836-8190

ENGINEER'S CANAL PUMP STATION IMPROVEMENTS
NORCO, ST. CHARLES PARISH, LA, DEC. 2015

VICINITY MAP

SHT. 1/7 VICINITY MAP
N.T.S.



EASEMENT NO. DACW29-2-95-08
EXHIBIT B



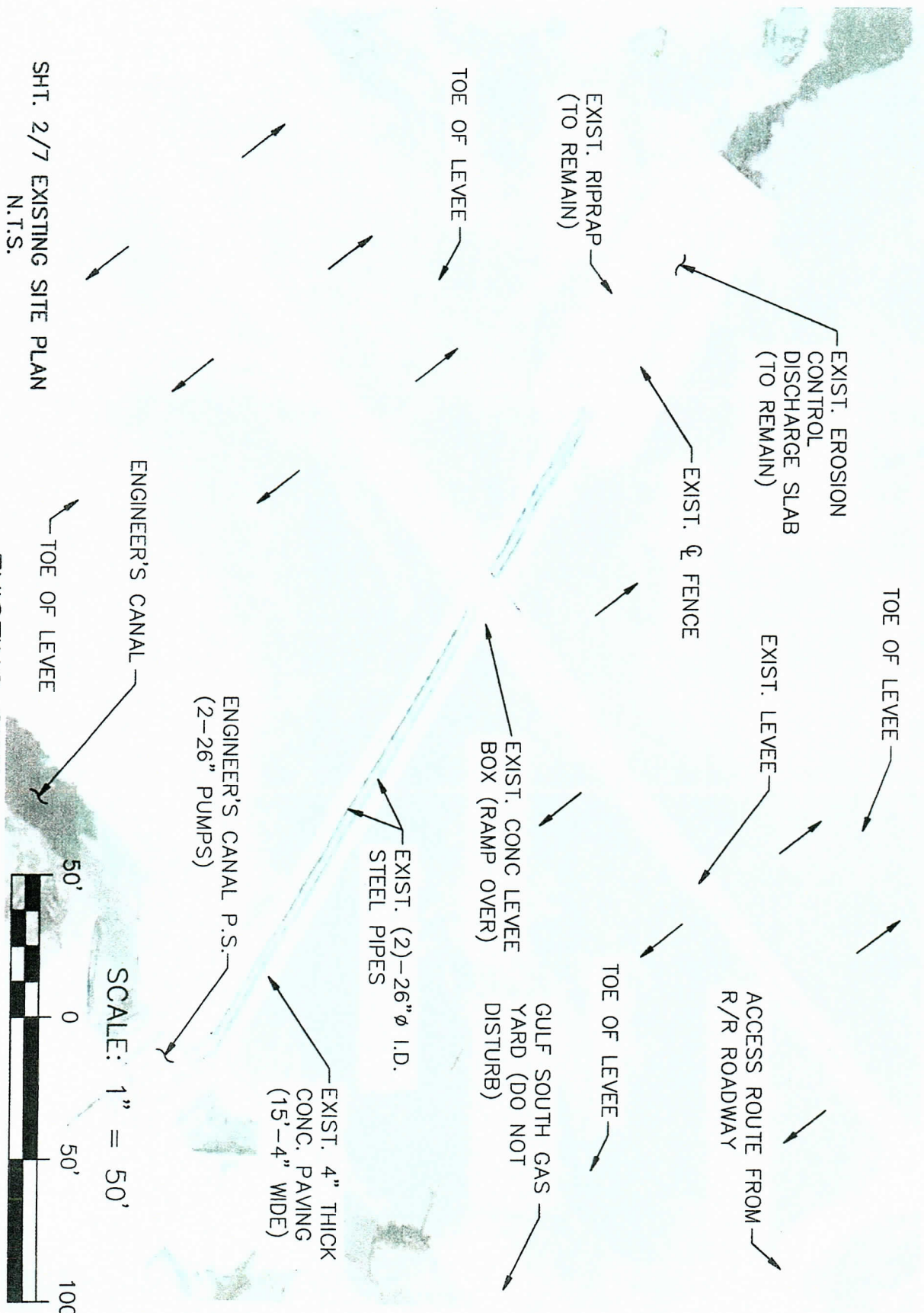

EASEMENT NO. DACW29-2-95-08
EXHIBIT B



EXISTING SITE

SHT. 2/7 EXISTING SITE PLAN
N.T.S.



EVANS-GRAVES ENGINEERS, INC.
ENGINEERING CONSULTANTS ONE GALLERIA BLVD. Ste 1520, METAIRIE, LA. 70001 (504) 836-8190

ENGINEER'S CANAL PUMP STATION IMPROVEMENTS
NORCO, ST. CHARLES PARISH, LA, DEC. 2015



EVANS-GRAVES ENGINEERS, INC.
 ENGINEERING CONSULTANTS ONE GALLERIA BLVD. Ste 1520, METAIRIE, LA. 70001 (504) 836-6190

ENGINEER'S CANAL PUMP STATION IMPROVEMENTS
 NORCO, ST. CHARLES PARISH, LA, DEC. 2015

SHT. 3/7 PROPOSED SITE PLAN
 N.T.S.

PROPOSED SITE

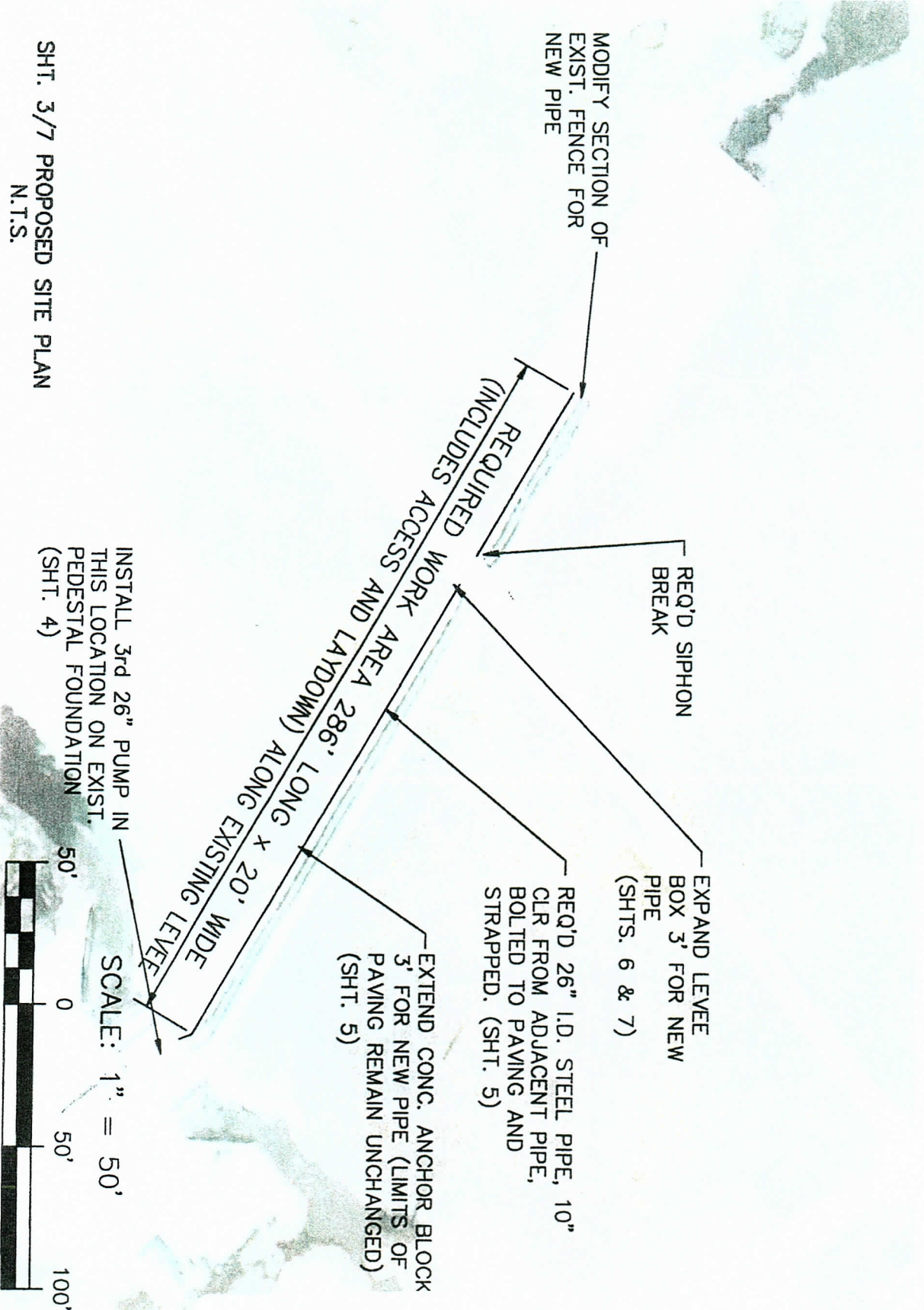

EASEMENT NO. DACW29-2-95-08
 EXHIBIT B

NOTE:
NO EXCAVATION OR DEMOLITION
REQUIRED ON THIS SHEET.

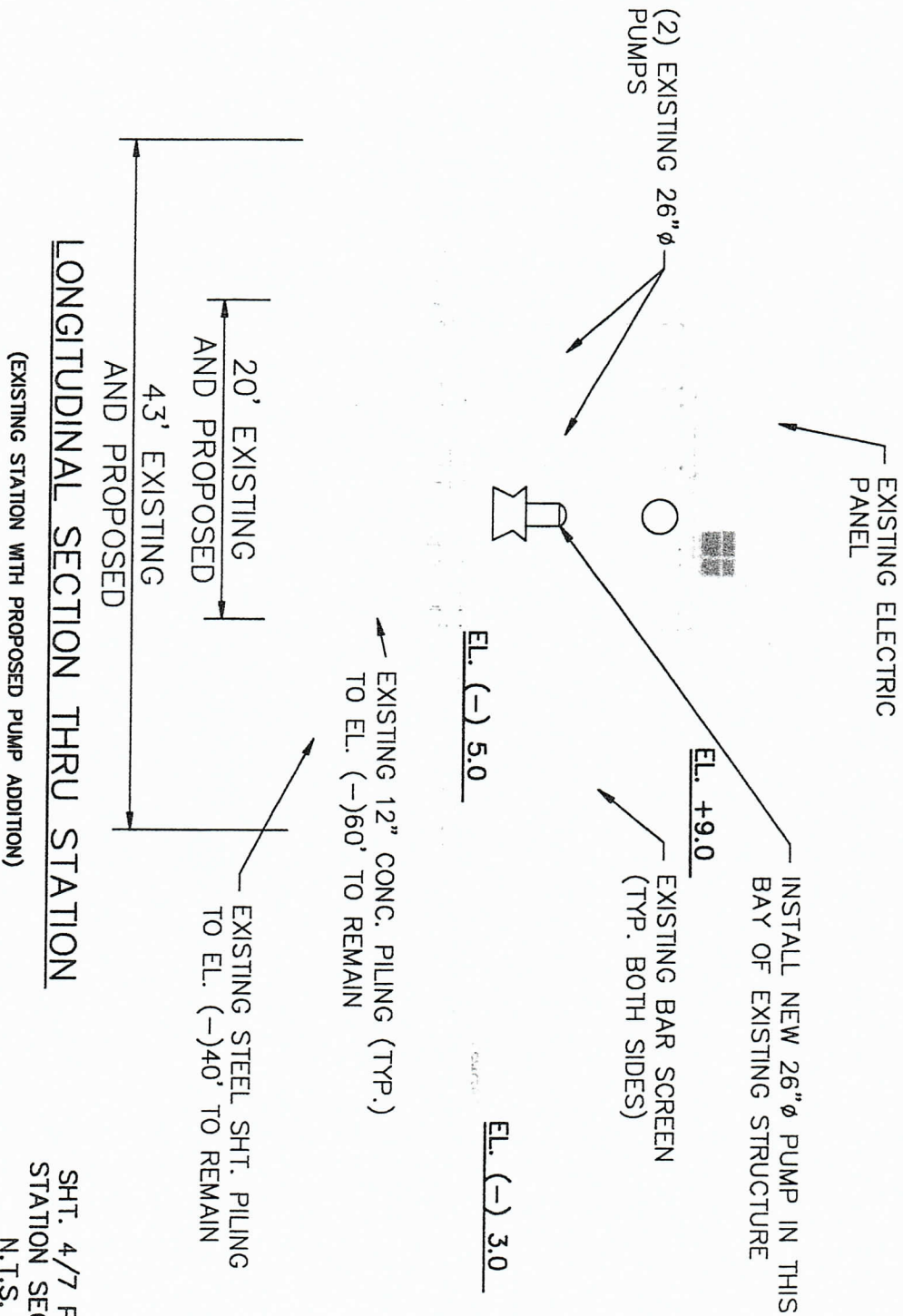

LONGITUDINAL SECTION THRU STATION

(EXISTING STATION WITH PROPOSED PUMP ADDITION)

SHT. 4/7 PUMP
STATION SECTION
N.T.S.



EVANS-GRAVES ENGINEERS, INC.
ENGINEERING CONSULTANTS ONE GALLERIA BLVD. Ste 1520, METAIRIE, LA. 70001 (504) 836-8190

ENGINEER'S CANAL PUMP STATION IMPROVEMENTS
NORCO, ST. CHARLES PARISH, LA, DEC. 2015

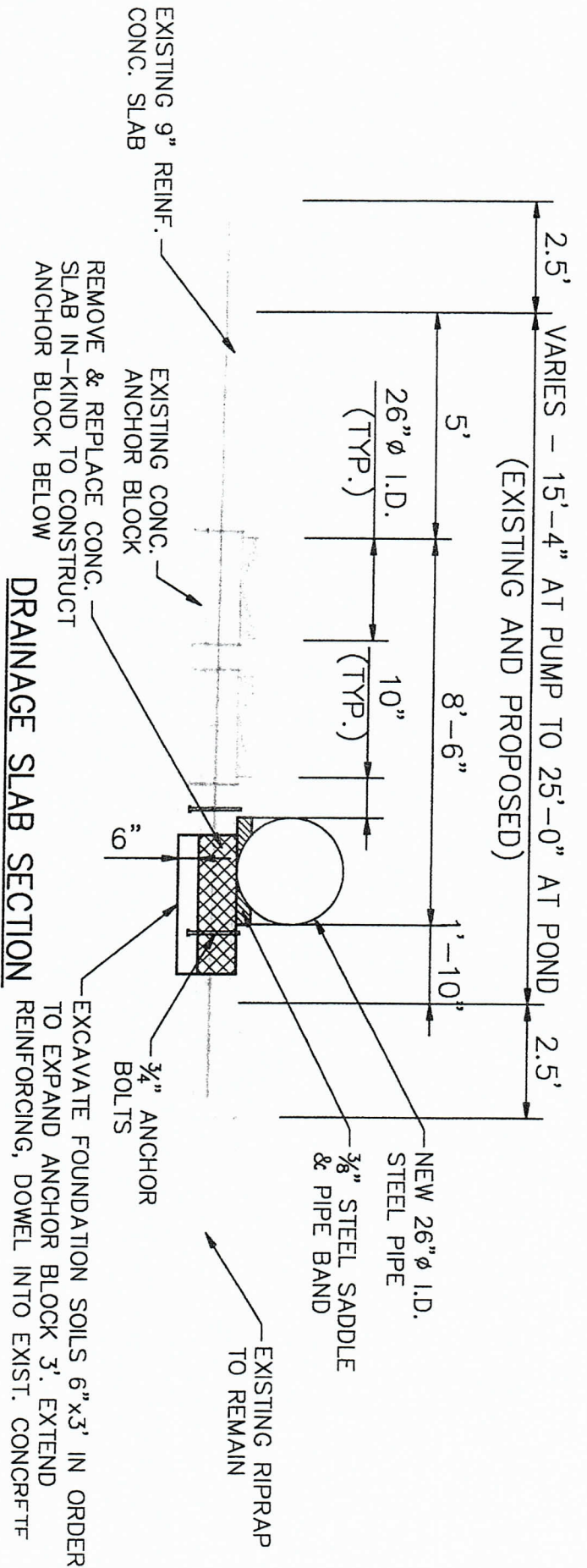

1. AS-BUILT DRAWINGS AND/OR PLATS SHALL HAVE WRITTEN ON THEM THE DATE OF COMPLETION OF SAID ACTIVITIES AND SHALL BE SUBMITTED TO THE LOUISIANA DEPARTMENT OF NATURAL RESOURCES, OFFICE OF COASTAL MANAGEMENT, P. O. BOX 44487, BATON ROUGE, LA 70804-4487 WITHIN 30 DAYS FOLLOWING PROJECT COMPLETION.
2. ALL STRUCTURES BUILT UNDER THE AUTHORIZATION AND CONDITIONS OF THIS PERMIT SHALL BE REMOVED FROM THE SITE WITHIN 120 DAYS OF ABANDONMENT OF THE FACILITIES FOR THE HEREIN PERMITTED USE, OR WHEN THESE STRUCTURES FALL INTO A STATE OF DISREPAIR SUCH THAT THEY CAN NO LONGER FUNCTION AS INTENDED. THIS CONDITION DOES NOT PRECLUDE THE NECESSITY FOR REVISING THE CURRENT PERMIT OR OBTAINING A SEPARATE COASTAL USE PERMIT, SHOULD ONE BE REQUIRED, FOR SUCH REMOVAL ACTIVITIES.
3. STRUCTURES MUST ALSO BE MARKED/LIGHTED IN ACCORDANCE WITH U. S. COAST GUARD REGULATIONS.
4. IN ORDER TO ENSURE THE SAFETY OF ALL PARTIES, THE PERMITTEE SHALL CONTACT THE LOUISIANA ONE CALL SYSTEM (1-800-272-3020) A MINIMUM OF 48 HOURS PRIOR TO THE COMMENCEMENT OF ANY EXCAVATION (DIGGING, DREDGING, JETTING, ETC.) OR DEMOLITION ACTIVITY.

EASEMENT NO. DACW29-2-95-08
EXHIBIT B

SHT. 5/7 PIPING SECTION
N.T.S.

EVANS-GRAVES ENGINEERS, INC.
ENGINEERING CONSULTANTS ONE GALLERIA BLVD. Ste 1520, METAIRIE, LA. 70001 (504) 838-8190

ENGINEER'S CANAL PUMP STATION IMPROVEMENTS
NORCO, ST. CHARLES PARISH, LA, DEC. 2015

NOTE:
EXCAVATED MATERIAL TO BE
HAULED OFF-SITE AND DISPOSED
OF LEGALLY AND PROPERLY
IN A NON-WETLANDS DISPOSAL
AREA

TOP OF LEVEE
(PLAN VIEW)

SHT. 6/7 LEVEE CROSSING PLAN
N.T.S.

"LEVEE BOX" CONCRETE CROSSING STRUCTURE,
SEE SHIT. 7. EXPAND EXIST. BOX 3' TO ACCOMMODATE
NEW PIPE. RESTORE COMPACTED CLAY FILL AND
GRASS WHERE DISTURBED.

EXCAVATE LEVEE CROWN
10' WIDE x 3'-6" LONG x 3'-8" DEEP
TO EXPAND EXISTING LEVEE
CROSSING 3' FOR NEW PIPE

EASEMENT NO. DACW29-2-95-08
EXHIBIT B

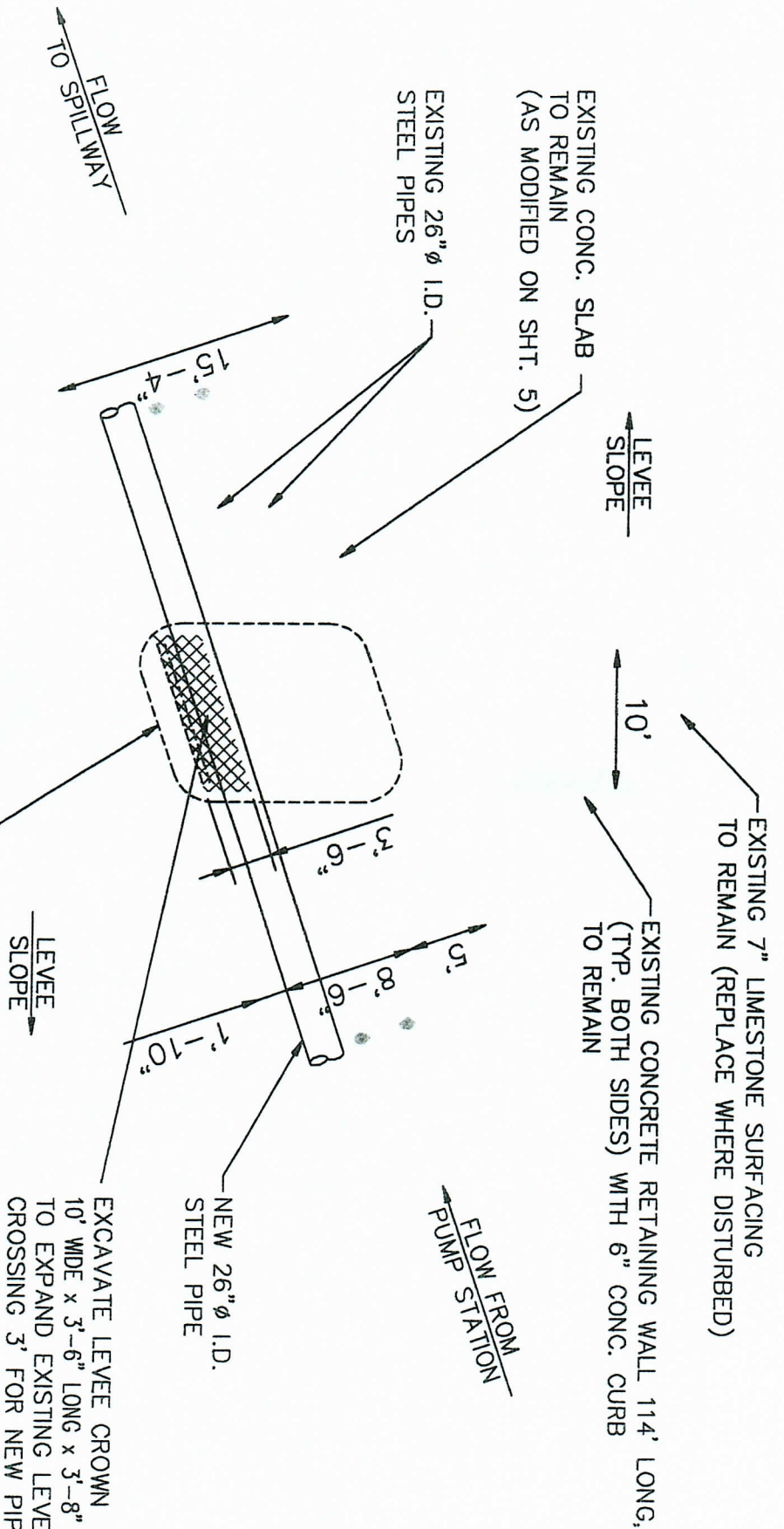

EVANS-GRAVES ENGINEERS, INC.
ENGINEERING CONSULTANTS ONE GALLERIA BLVD. Ste 1320, METAIRIE, LA. 70001 (504) 838-8190

ENGINEER'S CANAL PUMP STATION IMPROVEMENTS
NORCO, ST. CHARLES PARISH, LA, DEC. 2015

NOTE:
EXCAVATED MATERIAL TO BE
HAULED OFF-SITE AND DISPOSED
OF LEGALLY AND PROPERLY
IN A NON-WETLANDS DISPOSAL
AREA

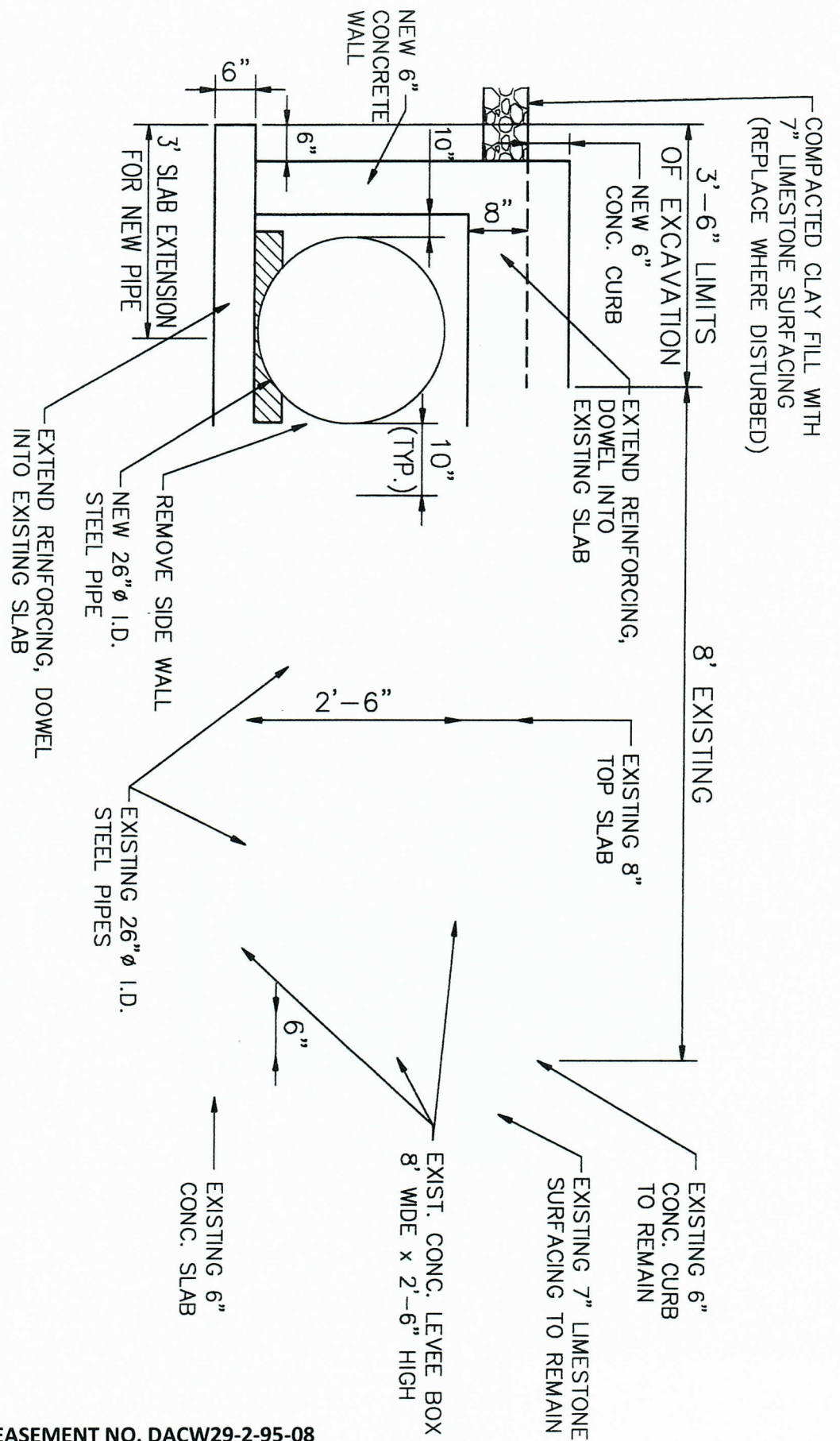

LEVEE BOX

(EXISTING BOX WITH PROPOSED ADDITION)

SHT. 7/7 LEVEE BOX EXPANSION
N.T.S.

EASEMENT NO. DACW29-2-95-08
EXHIBIT B

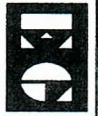

EVANS-GRAVES ENGINEERS, INC.
ENGINEERING CONSULTANTS ONE GALLERIA BLVD. Ste 1520, METAIRIE, LA. 70001 (504) 836-8190

ENGINEER'S CANAL PUMP STATION IMPROVEMENTS
NORCO, ST. CHARLES PARISH, LA, DEC. 2015