

RP-1 (9 units per acre)

Minimum Lot Size:

4,800 square feet

Minimum Lot Width:

40 feet

Maximum Buildable Area:

2,800 square feet.

Minimum Setbacks:

Front: 20 feet

Rear: 20 feet

Side: 0 feet one side, and
minimum setback of 10 feet
between adjacent structures.

SAMPLE
LOT
SIZES
AND
LAYOUTS

4,800 SQ. FT.
(40 X 120)

4,950 SQ. FT.
(45 X 110)

5,000 SQ. FT.
(50 X 100)

5,500 SQ. FT.
(50 X 110)

RESULT IN
BUILDABLE
AREAS
OF

2,400 SQ. FT.
(30 X 80)

2,450 SQ. FT.
(35 X 70)

2,400 SQ. FT.
(40 X 60)

2,800 SQ. FT.
(40 X 70)

(NOT TO SCALE)

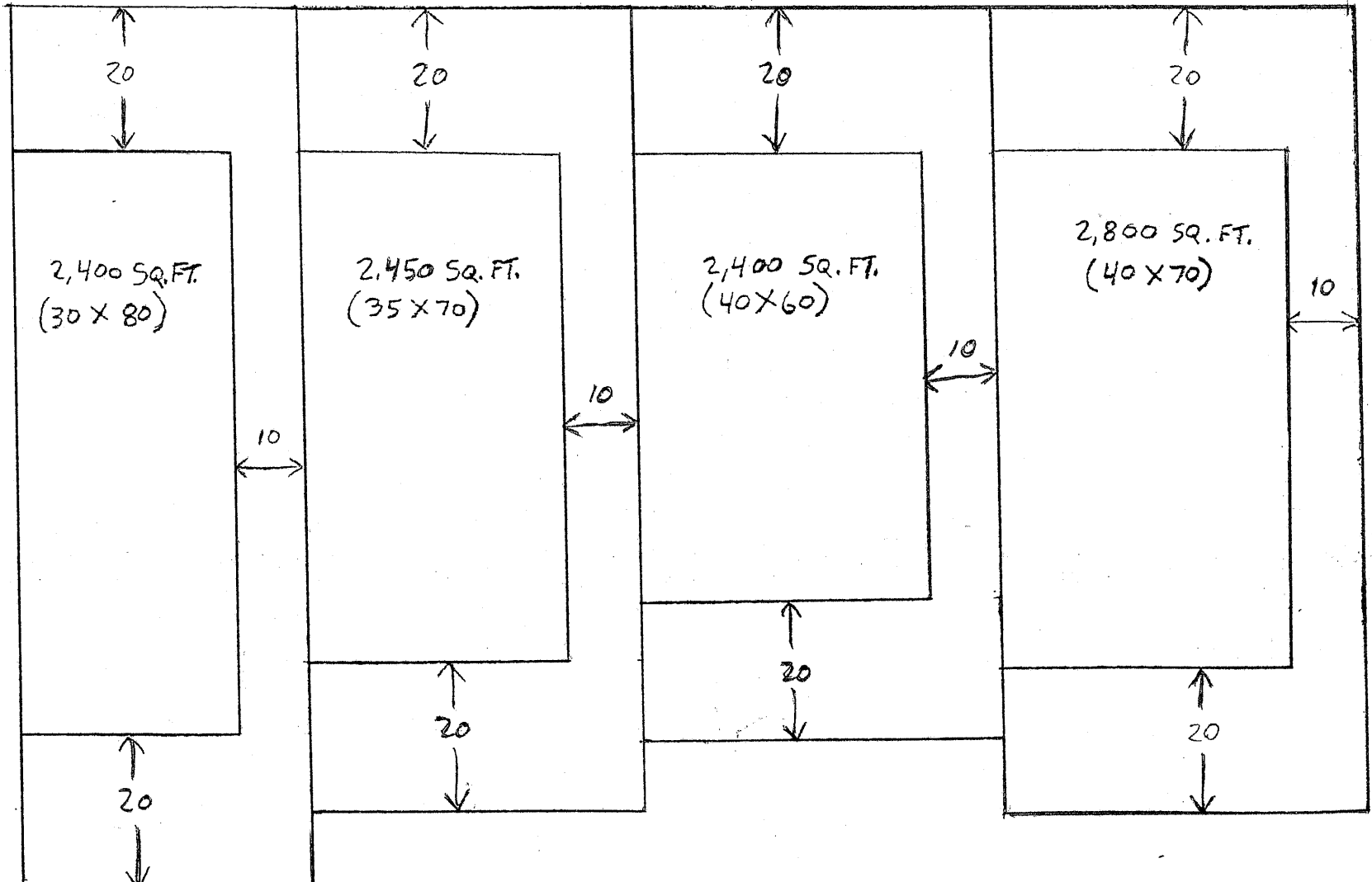

RP-1(A) (12 units per acre)

Minimum Lot Size:

3,600 square feet

Minimum Lot Width:

30 feet

Maximum Buildable Area:

2,125 square feet.

Minimum Setbacks:

Front: 20 feet

Rear: 20 feet

Side: 0 feet one side,
minimum setback of 10 feet
between adjacent structures.

SAMPLE
LOT
SIZES
AND
LAYOUTS



3,750 SQ. FT.
(30 X 125)

3,675 SQ. FT.
(35 X 105)

3,600 SQ. FT.
(37.5 X 96)

4,500 SQ. FT.
(45 X 100)

20

20

20

20

20

20

20

20

1,700
SQ. FT.
(20 X 85)

10

1,625
SQ. FT.
(25 X 65)

10

1,540
SQ. FT.
(27.5 X 56)

10

2,100
SQ. FT.
(35 X 60)

10

20

20

20

20

20

20

20

20

RESULT IN
BUILDABLE
AREAS
OF



(NOT TO SCALE)

