

2002-0401

INTRODUCED BY: ALBERT D. LAQUE, PARISH PRESIDENT
(DEPARTMENT OF PUBLIC WORKS)

ORDINANCE NO. 02-10-7

An ordinance approving and authorizing the execution of Change Order No One (1) for Parish Project No. P980701 Willowdale Drainage Pump Station to increase the size of the new triplex station from 360 CFS to 525 CFS, and increase the amount of the contract by \$473,714.00 in order to handle the entire West Bank Master Drainage Plan flow of 524 CFS with new pumps.

WHEREAS, Ordinance No. 02-6-1 adopted June 3, 2002 by the St. Charles Parish Council, approved and authorized the execution of a contract with D & O Contractors, Inc for the construction of Willowdale Drainage Pump Station in the amount of \$3,091,611.00; and,

WHEREAS, the pumps originally planed for use in this pump station did not meet the West Bank Master Drainage Plan's flow requirements; and,

WHEREAS, the purchase of larger pumps is required to meet the West Bank Master Drainage Plan flow requirements and an increase in the contract amount by \$473,714.00 is required.

THE ST. CHARLES PARISH COUNCIL HEREBY ORDAINS:

SECTION I. That Change Order No. One (1) to the contract for the Willowdale Drainage Pump Station to change the size of the new triplex station and to increase the contract amount to \$3,565,325.00 is hereby approved

SECTION II. That the Parish President is hereby authorized to execute said Change Order.

The foregoing ordinance having been submitted to a vote, the vote thereon was as follows:

YEAS: RAMCHANDRAN, FAUCHEUX, HILAIRE, FABRE, ABADIE, BLACK, MARINO, MINNICH

NAYS: NONE

ABSENT: AUTHEMENT

And the ordinance was declared adopted this 7th day of October, 2002, to become effective five (5) days after publication in the Official Journal.

CHAIRMAN.

SECRETARY.

DLVD/PARISH PRESIDENT:

APPROVED.

DISAPPROVED

PARISH PRESIDENT.

RETD/SECRETARY.

AT: 3:30 pm

RECD BY.

RECORDED IN THE ST. CHARLES PARISH
CLERK OF COURT OFFICE

ON 10-11-02

AS ENTRY NO. 271437

IN MORTGAGE/CONVEYANCE BOOK

NO. 878

FOLIO 480

October 8, 2002

October 8, 2002

CHANGE ORDER

No. 1

DATE OF ISSUANCE 18-Sep-02 EFFECTIVE DATE 18-Sep-02

OWNER St. Charles Parish (SCP) Department of Public Works and Wastewater
 CONTRACTOR D & O Contractors, Inc
 Contract: Willowdale Drainage Pump Station
 Project: Willowdale Drainage Pump Station
 OWNER's Contract No. P980701 ENGINEER's Contract No. N/A
 ENGINEER N-Y Associates, Inc.

You are directed to make the following changes in the Contract Documents:
 Description: See Attachment 1 - Description of Changes

Reason for Change Order: To increase the size of the new triplex station from 360 CFS to 525 CFS, in order to handle the entire Master Plan flow of 524 CFS with new pumps

Attachments: (List documents supporting change) Attachment 2 - Backup Material from Contractor.

CHANGE IN CONTRACT PRICE

Original Contract Price
\$3,091,611.00
 Net increase (decrease) from previous Change Orders
 No. 0 to No. 0
\$0.00
 Contract Price prior to this Change Order.
\$3,091,611.00
 Net increase (decrease) of this Change Order.
\$473,714.00
 Contract price with all approved Change Orders
\$3,565,325.00

CHANGE IN CONTRACT TIMES

Original Contract Times:
 Substantial Completion: August 2, 2003
 Ready for final payment: September 16, 2003
 (days or dates)
 Net change from previous Change Orders No. 0 to
 No. 0
 Substantial Completion: Zero
 Ready for final payment: Zero
 (days)
 Contract Times prior to this Change Order
 Substantial Completion: August 2, 2003
 Ready for final payment: September 16, 2003
 (days or dates)
 Net increase (decrease) this Change Order
 Substantial Completion: Zero
 Ready for final payment: Zero
 (days)
 Contract Times with all approved Change Orders
 Substantial Completion: August 2, 2003
 Ready for final payment: September 16, 2003
 (days or dates)

RECOMMENDED:

By: [Signature]
 ENGINEER (Authorized Signature)
 Date: 9/23/02

APPROVED:

By: [Signature]
 OWNER (Authorized Signature)
 Date: 10/8/2002

ACCEPTED:

By: [Signature]
 CONTRACTOR (Authorized Signature)
 Date: 9-23-02

EJCDC 1910-B-B (1996 Edition)

Prepared by the Engineers Joint Contract Documents Committee and endorsed by The Associated General Contractors of America and the Construction Specifications Institute

2002-0401

**INTRODUCED BY: ALBERT D. LAQUE, PARISH PRESIDENT
 (DEPARTMENT OF PUBLIC WORKS)**

ORDINANCE NO. 02-10-7

An ordinance approving and authorizing the execution of Change Order No. One (1) for Parish Project No P980701 Willowdale Drainage Pump Station to increase the size of the new triplex station from 360 CFS to 525 CFS, and increase the amount of the contract by \$473,714.00 in order to handle the entire West Bank Master Drainage Plan flow of 524 CFS with new pumps.

WHEREAS, Ordinance No. 02-6-1 adopted June 3, 2002 by the St. Charles Parish Council, approved and authorized the execution of a contract with D & O Contractors, Inc. for the construction of Willowdale Drainage Pump Station in the amount of \$3,091,611.00, and,

WHEREAS, the pumps originally planed for use in this pump station did not meet the West Bank Master Drainage Plan's flow requirements; and,

WHEREAS, the purchase of larger pumps is required to meet the West Bank Master Drainage Plan flow requirements and an increase in the contract amount by \$473,714.00 is required.

THE ST. CHARLES PARISH COUNCIL HEREBY ORDAINS:

SECTION I. That Change Order No. One (1) to the contract for the Willowdale Drainage Pump Station to change the size of the new triplex station and to increase the contract amount to \$3,565,325.00 is hereby approved.

SECTION II. That the Parish President is hereby authorized to execute said Change Order.

The foregoing ordinance having been submitted to a vote, the vote thereon was as follows:

YEAS: RAMCHANDRAN, FAUCHEUX, HILAIRE, FABRE, ABADIE, BLACK, MARINO, MINNICH
 NAYS: NONE
 ABSENT: AUTHEMENT

ATTACHMENT 1 - DESCRIPTION OF CHANGES

BASE BID FOR PARISH PROJECT NO. P980701: WILLOWDALE DRAINAGE PUMP STATION

Item No.	Description	Unit	Unit Price	Quantity	Original Contract Cost	Change Order No. 1 Quantity	Change Order No. 1 Cost	Total to Date Quantity	Total to Date Cost	Increases	Decreases	Deletions	Additions
1	Mobilization	LS	\$75,000.00	1.00	\$75,000.00			1.00	\$75,000.00	\$26,421.00			
2	Temporary Signs and Banners	LS	\$1,400.00	1.00	\$1,400.00			1.00	\$224,123.00				
3	Project Sign	EA	\$400.00	1.00	\$400.00			1.00	\$31,672.00				
4	Pre-Engineered Metal Building	LS	\$14,050.00	1.00	\$14,050.00			1.00	\$41,275.00				
5	Pump Station Structure	LS	\$280,000.00	1.00	\$280,000.00			1.00					
6	Drainage Pump and Gear Reducer Assembly	EA	\$350,000.00	3.00	\$1,050,000.00			3.00					
7	Diesel Engines	EA	\$31,000.00	3.00	\$93,000.00			3.00					
8	Discharge Piping	EA	\$18,000.00	3.00	\$54,000.00			3.00					
9	Intake Basin	LS	\$660,000.00	1.00	\$660,000.00			1.00					
10	Discharge Basin	LS	\$100,000.00	1.00	\$100,000.00			1.00					
11	Bar Screen	LS	\$15,000.00	1.00	\$15,000.00			1.00					
12	Walkways, Stairs, Handrails and Gratings	LS	\$19,000.00	1.00	\$19,000.00			1.00					
13	Overhead Crane	LS	\$5,500.00	1.00	\$5,500.00			1.00					
14	Electrical and Motor Control Center	LS	\$120,000.00	1.00	\$120,000.00			1.00					
15	Fuel Oil Storage Tank and Day Tank	LS	\$35,000.00	1.00	\$35,000.00			1.00					
16	Emergency Generator	EA	\$12,000.00	1.00	\$12,000.00			1.00					
17	Seal Water System	LS	\$3,100.00	1.00	\$3,100.00			1.00					
18	Test Pile	EA	\$22,000.00	2.00	\$44,000.00			2.00					
19	Fencing and Gates	LS	\$3,500.00	1.00	\$3,500.00			1.00					
20	General Excavation and Grading	LS	\$250,000.00	1.00	\$250,000.00			1.00					
21	Crushed Limestone Parking Area and Limestone Roadway (Truck Measured)	CY	\$33.00	370.00	\$12,210.00			370.00					
22	Class "D" Geotextile	SY	\$1.00	6000.00	\$6,000.00			6000.00					
23	Crushed Stone for Base Course and Shoulder Roadway (Truck Measured)	CY	\$44.00	1240.00	\$54,560.00			1240.00					
24	Hot Mix Asphalt Wearing Course (1-1/2" Thick)	SY	\$3.00	3700.00	\$11,100.00			3700.00					
25	Hot Mix Asphalt Wearing Course (3-1/2" Thick)	SY	\$10.00	3700.00	\$37,000.00			3700.00					
26	Rip Rap (Truck Measure)	CY	\$100.00	300.00	\$30,000.00			300.00					
27	Drop Inlets	EA	\$3,500.00	3.00	\$10,500.00			3.00					
28	12" Diameter PVC Drainline	LF	\$125.00	70.00	\$8,750.00			70.00					
29	15" Diameter PVC Drainline	LF	\$150.00	50.00	\$7,500.00			50.00					
30	18" Diameter PVC Drainline	LF	\$160.00	35.00	\$5,600.00			35.00					
31	8" PVC Water Main Including Fittings	LF	\$10.00	2330.00	\$23,300.00			2330.00					
32	Water Line Tie-In at Willowdale Blvd	LS	\$3,500.00	1.00	\$3,500.00			1.00					
33	8" D.J. Water-Main Aerial Crossing	LS	\$4,500.00	1.00	\$4,500.00			1.00					
34	8" Water Valve and Box	EA	\$1,800.00	1.00	\$1,800.00			1.00					
35	4" Water Valve and Box	EA	\$350.00	1.00	\$350.00			1.00					
36	2" PVC Waterline Including Fittings	LF	\$12.00	70.00	\$840.00			70.00					
37	Fire Hydrants	EA	\$1,600.00	5.00	\$8,000.00			5.00					
38	2" Water Meter	EA	\$1.00	1.00	\$1.00			1.00					
39	2" Water Backflow Preventer	EA	\$1,200.00	1.00	\$1,200.00			1.00					
40	Relocation of Infrastructure Items	LS	\$30,000.00	1.00	\$30,000.00			1.00					
X-1	Increase in Engine Cost	LS	\$26,421.00	1.00			\$26,421.00	1.00	\$26,421.00				
X-2	Change From 48" to 54" Pumps	LS	\$224,123.00	1.00			\$224,123.00	1.00	\$224,123.00				
X-3	Sump Modifications	LS	\$31,672.00	1.00			\$31,672.00	1.00	\$31,672.00				
X-4	Change Discharge Pipe From 48" to 54"	LS	\$41,275.00	1.00			\$41,275.00	1.00	\$41,275.00				

ATTACHMENT 2
CORRESPONDENCE

X-5	Additional Mechanical Work	LS	\$9,431.00	1.00	\$9,431.00	\$9,431.00				
X-6	Additional Electrical Work	LS	\$5,600.00	1.00	\$5,600.00	\$5,600.00				
X-7	Demolition of Existing Pump Station	LS	\$12,721.00	1.00	\$12,721.00	\$12,721.00				
X-8	10' x 6' Box Culvert at Willowdale	LF	\$950.00	80.00	\$76,000.00	\$76,000.00				
X-9	10' x 10' Box Culvert for Pump Station Access	LF	\$975.00	45.00	\$44,875.00	\$43,875.00				\$6,700.00
X-10	Credits for Waterline Crossing	LS	-\$6,700.00	1.00	-\$6,700.00					
X-11	Removal of Existing 96" Dia CMP	LS	\$3,140.00	1.00	\$3,140.00	\$3,140.00				
X-12	Extra for Traffic Control & Detour at Willowdale Blvd	LS	\$6,156.00	1.00	\$6,156.00	\$6,156.00				

TOTALS \$3,091,611.00 \$473,714.00 \$0.00 \$473,714.00 \$6,700.00 \$0.00 \$0.00

RESULTING INCREASE TO BASE BID \$473,714.00



D&O CONTRACTORS, INC.

98022
og File
CC FN
MFN
CFN
REB
AM

FAX SHEET

TO: Amritendu Maji	FROM: Dan Wagner
COMPANY: N-Y Associates	DATE: September 19, 2002
PHONE #: (504) 885-0500	# OF PAGES INC. COVER: 5
FAX #: (504) 885-0595	OUR PHONE & FAX #: (504) 466-1257 & (504) 461-5971
RE: Willowdale	

URGENT FOR REVIEW PLEASE COMMENT PLEASE REPLY PLEASE COMPLY

Please see attached.

Thank You



2207 GREENWOOD STREET
KENNER, LA 70062



D&O CONTRACTORS, INC.
EST. 1975

September 19, 2002

N-Y Associates, Inc.
2750 Lake Villa Drive
Metairie, LA 70002
Attn: Amritendu Maji, P.E.

RE: Willowdale Pump Station

Dear Mr. Maji:

We propose to furnish labor, material and equipment to install three (3) each fifty-four (54) inch Verti-Line pumps for the additional sum of \$473,714.00. This proposal includes all items to increase pumps, engines, discharge pipe, along with sump modifications as outlined in Pentair's letter (copy attached). It also includes demolition and removal of existing stations and construction of one (1) 10'x8' box culvert at Willowdale Blvd. Along with one (1) 10'x8' box culvert at the pump station site. Our cost is compiled as follows:

Increased Engine Cost Quote No. 02EPS102-03	\$26,421.00
Increased Pump Cost	\$224,123.00
Sump Modifications	\$31,672.00
Increases Discharge Pipe Cost	\$41,275.00
Additional Mechanical Cost	\$9,431.00
Additional Electrical Cost	\$5,600.00
Demo Ext. Stations	\$12,721.00
Box Culvert at Willowdale Blvd.	\$82,156.00
Box Culvert at Station	\$47,015.00
Credit for Waterxing	\$-6,700.00

Sincerely,

Dan Wagner
Project Manager

2207 GREENWOOD STREET - KENNER, LOUISIANA - 70062
PHONE: (504) 466-1257 + FAX: (504) 461-5971
LOUISIANA LICENSE NO. 9998



September 10, 2002

Parson & Sanderson, Inc.
405 Commerce Point
Harahan, LA 70123

Subject: Willowdale Drainage Pump Station

Dear Mr. Leedy:

Per your conversation with Arnie Sdano, Director of Engineering, you discussed three options to reduce sub-surface vortices. Attached with this letter is the option you settled on, as shown in drawing T-063330. The dimensions in the drawing are based on the anticipated bell diameter size of 85.5".

We confirm that the measures you are undertaking via the addition of fillets and splitters will reduce the probability of vortices to the point where Layne/Verti-Line will guarantee the performance of the pumps in the modified sump when operating at the rated flow and speed while at the "pump off" intake elevation of -6.0 feet. We also confirm that the pumps can be operated at a reduced pump speed of 293 RPM down to an intake elevation of -7.5 feet in order to draw down the suction canal in advance of an approaching storm. These guarantees are based on the pump station drawing (G-3) supplied to Layne/Verti-Line showing the vent/vacuum breaker, which we assume, is always open and that the siphon is never established.



Brenette Wilder
Product Engineer

Arnie R. Sdano - P.E.
Director of Engineering

cc: Mike Willey, Director of Marketing
Manjit Sagoo, Sr. Staff Engineer

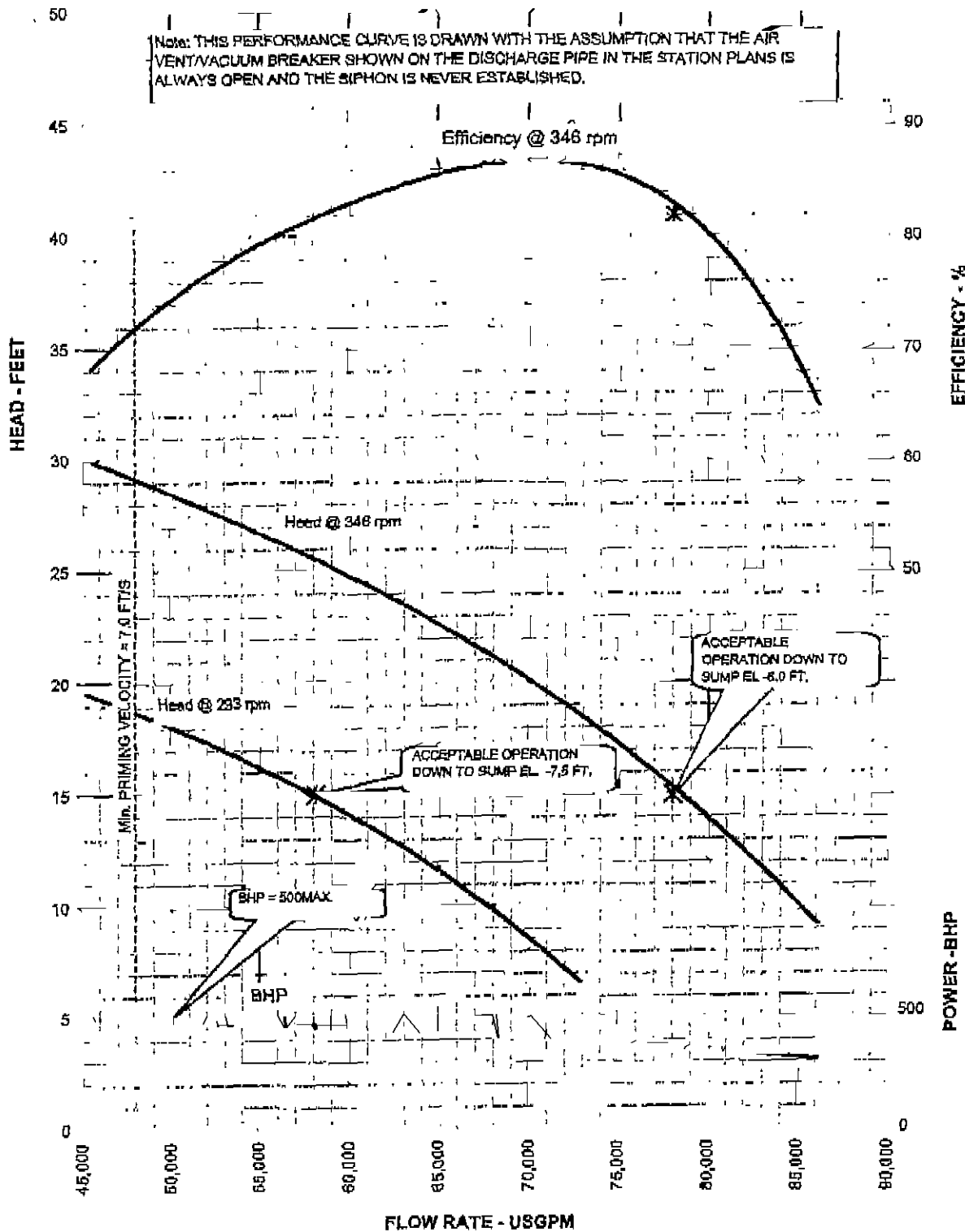

Pump Performance Curve
Pump Size: 54"6310 Willowdale
72000 GPM @ 15.0 Feet Head @ 346 rpm, IMP 47.0



DRAWN BY
B. WILDER

DATE
8/02

DESIGNED BY
A. SDANO

DATE
8/10

ENGINEERING APPROVAL
B. WILDER

DATE
9/10

PLUM
S4-6310

DATE

REV

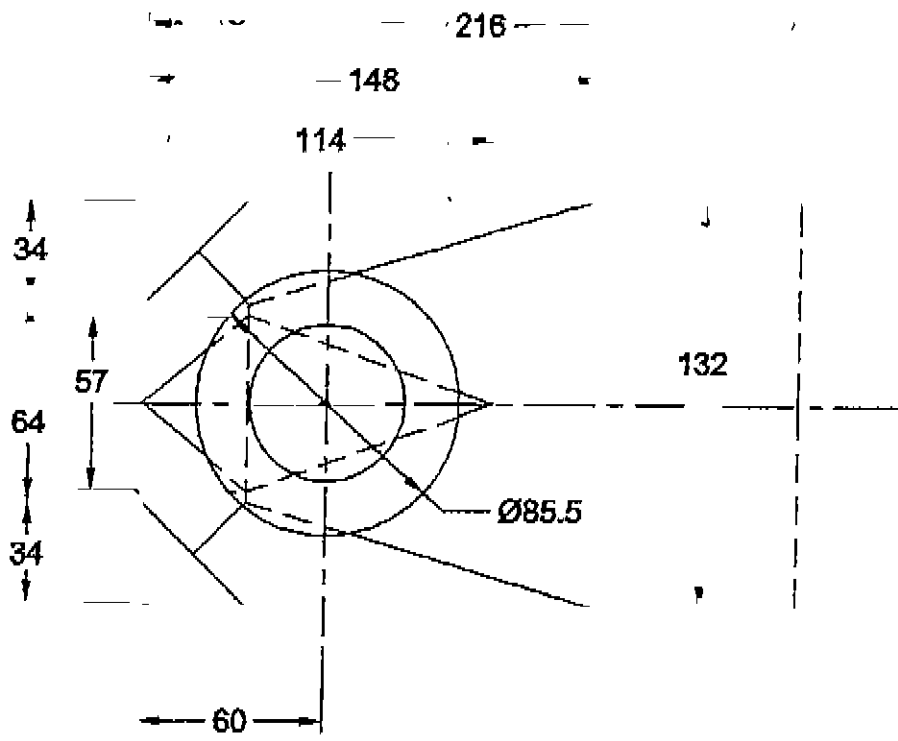
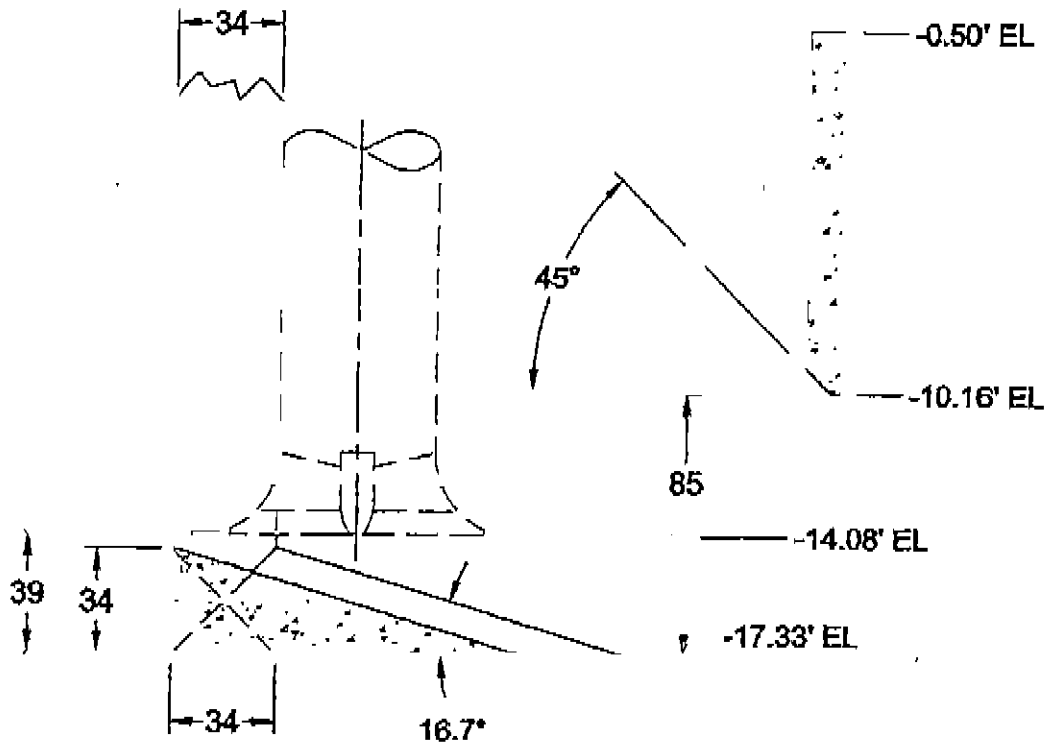

ALL DIMENSIONS IN INCHES

WILLOWDALE DRAINAGE P.S.
SUMP DESIGN

DESIGNED BY: A. SDANO
DRAWN BY: B. WILDER
DWG NO: T-063330
REV NO: 0

98025
ccg F&I
CCFN
MFA
CFN
AM
REI



**Louisiana
Machinery
Power Systems**

2011 Engineers Road
Belle Chasse, LA 70037
Phone 504-393-5050 FAX 504-391-0107

SEP 12 2002



Fax Transmittal

To:	Amritendu Maji	Fax:	885-0595
	Jeff Leedy		736-9348
From:	Gary P Sarrat Jr	Date:	9/12/02
Re:	Willowdale	Pages:	6

Maji,

I was able to get the 525Hp rating out of the same 3406 that was selected and quoted earlier. The rating as we discussed earlier is not continuous per se. This 'E' rating is for standby centrifugal pumps. The engine is capable of running the duration of the pumping emergency continuously, then idle for days or weeks. The typical duty cycle would be 500-800hrs per year, which will fall under this application. The good news is that all our installation sizes remain the same since we are using the same engine model. The bad news is that there is an increase in pricing for the added HP. I have sent Dan the quote detailing the use of this engine, and also included the pricing for the pump package control panels (one per pkg) that was not priced out at bid time. I have also included in the fax a cut sheet on the engine we will be using the E rating, which will get 514HP at 1800rpm. Let me know if you have any questions.

Thanks,

Gary Sarrat Jr
Industrial Engine Sales



Industrial Engine 3406C

322-525 bhp/240-392 kW
1800-2100 rpm

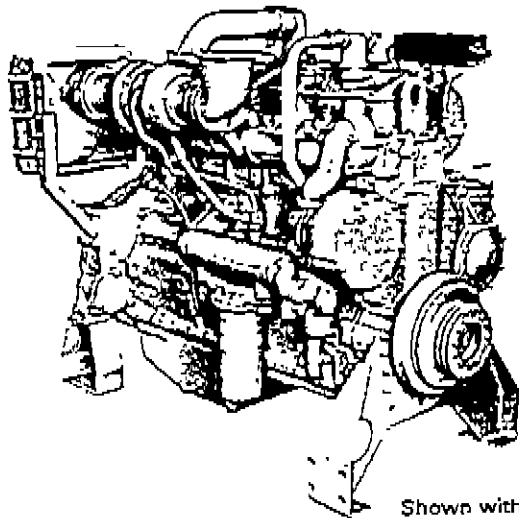

Shown with
Optional Equipment

FEATURES

- **FUEL ECONOMY**
Consistent performance, variable-timed fuel injection, broad rpm turbocharger match, excellent fuel economy over entire operating range.
- **RELIABILITY AND DIESEL DURABILITY**
Diesel tough components, precise balance, and conservative speed for smooth operation and long engine life.

CATERPILLAR® ENGINE SPECIFICATIONS

In-Line, 6 Cylinder, 4-Stroke-Cycle Diesel

Bore — in (mm)	5.4 (137)
Stroke — in (mm).....	6.5 (165)
Displacement — cu in (L).....	893 (14.6)
Low Idle (rpm)	600
Rotation (from flywheel end) ..	Counterclockwise
Capacity for Liquids — U.S. Gal (L)	
Cooling System (engine only).....	9.0 (34.1)
Lube Oil System (refill).....	9.0 (34.1)
Weight, Net Dry (approx) — lb (kg)	
Including Flywheel.....	2990 (1356)

- **FLEXIBLE APPLICATION RANGE**
High torque rise, big displacement, convenient installation, more performance for your money.
- **WORLDWIDE PRODUCT SUPPORT AND PARTS AVAILABILITY**

STANDARD EQUIPMENT

- Air intake
single-stage, dry air cleaner
- Cooling
thermostats and housing, centrifugal gear-driven jacket water
- Exhaust
6-inch dry elbow
- Fuel
filter, priming and transfer pumps
- Flywheel and flywheel housing, SAE No. 1
- Instruments and gauges
instrument panel, fuel pressure, lube oil pressure and water temperature gauge, service meter
- Lube
filter, oil cooler
- Supports

OPTIONAL EQUIPMENT

- Air Compressor
- Air Intake
heavy-duty air cleaner, muffler, precleaner
- Alternators
- Cooling
expansion tank, heat exchanger, radiator, fans, fan drives, auxiliary water pump, dry charge coolant conditioner
- Exhaust
flexible fittings, mufflers, watercooled manifolds and turbos, flanges
- Instruments and gauges
premium panel 8-gauge, tachometers, tach drives
- Power Takeoffs
auxiliary drives, enclosed clutches, hydraulic pumps, stub shaft
- Protection Devices
alarm switches, oil and water shutoffs, electric and mechanical
- Starting
air, electric





3406C INDUSTRIAL ENGINE

PERFORMANCE DATA

Turbocharged-Aftercooled PA5188

Rating Level	E			D			C			B			A		
Rated rpm	2100			2100			2100			2000			1800		
Engine Power @ rpm	525 bhp (392 bkW)			515 bhp (384 bkW)			450 bhp (343 bkW)			440 bhp (328 bkW)			420 bhp (313 bkW)		
rpm	2100	1800	1500	2100	1800	1500	2100	1800	1500	2000	1800	1500	1800	1700	1500
bhp	525	501	456	515	499	451	460	446	403	440	429	391	420	431	415
lb/bhp-hr	.367	.355	.352	.339	.332	.334	.339	.330	.330	.335	.330	.330	.331	.332	.333
gal/hr	27.4	25.4	22.8	24.9	23.6	21.5	22.3	21.0	19.1	21.0	20.2	18.4	19.8	20.3	19.7
bkW	392	374	340	384	372	337	343	332	301	328	320	291	313	321	309
g/bkW-hr	223	216	214	206	202	203	206	201	201	204	201	201	201	202	203
L/hr	103.9	96.0	86.4	94.4	89.4	81.3	84.3	79.5	72.2	79.6	76.6	69.8	75.1	77.0	74.5

PERFORMANCE DATA

Turbocharged-Aftercooled PA2373

Rating Level	E			D			C			B			A		
Rated rpm	2100			2100			2100			2000			1800		
Engine Power @ rpm	500 bhp (373 bkW)			480 bhp (358 bkW)			400 bhp (298 bkW)			370 bhp (276 bkW)			325 bhp (242 bkW)		
rpm	2100	1800	1500	2100	1800	1500	2100	1800	1500	2000	1800	1500	1800	1700	1500
bhp	500	485	437	480	464	419	400	377	341	370	356	324	325	327	310
lb/bhp-hr	.339	.332	.332	.339	.330	.332	.339	.329	.330	.334	.329	.332	.329	.329	.332
gal/hr	24.2	22.9	20.7	23.2	21.9	19.9	19.4	17.8	16.1	17.7	16.7	15.3	15.3	15.3	14.7
bkW	373	360	326	358	346	313	298	282	254	276	266	241	242	244	232
g/bkW-hr	206	202	202	206	201	202	206	200	201	203	200	202	200	200	202
L/hr	91.7	86.5	78.4	87.9	82.9	75.2	73.4	67.2	60.9	66.9	63.4	58.0	57.8	58.0	55.7

PERFORMANCE DATA

Turbocharged-Aftercooled PA2376

Rating Level	E			D			C			B			A		
Rated rpm	2100			2100			2100			2000			1800		
Engine Power @ rpm	450 bhp (336 bkW)			420 bhp (313 bkW)			360 bhp (269 bkW)			325 bhp (242 bkW)			322 bhp (240 bkW)		
rpm	2100	1800	1500	2100	1800	1500	2100	1800	1500	2000	1800	1500	1800	1700	1500
bhp	450	426	386	420	398	360	360	339	306	325	312	293	322	318	296
lb/bhp-hr	.339	.330	.330	.339	.329	.330	.340	.329	.332	.337	.330	.334	.333	.332	.334
gal/hr	21.8	20.1	18.2	20.3	18.7	17.0	17.5	15.9	14.5	15.6	14.3	13.4	15.3	15.0	14.1
bkW	336	318	288	313	297	268	269	253	229	242	233	211	240	237	221
g/bkW-hr	206	201	201	206	200	201	207	200	202	205	201	203	203	202	203
L/hr	82.4	76.0	68.9	77.0	70.8	64.3	66.3	60.3	54.8	59.2	55.7	50.9	58.0	56.9	53.5

3406C INDUSTRIAL ENGINE



PERFORMANCE CURVES

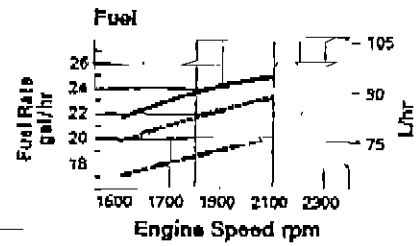
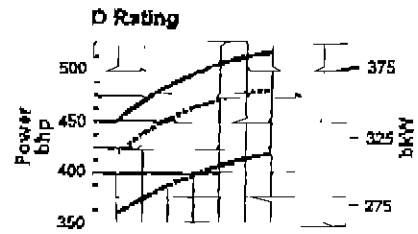
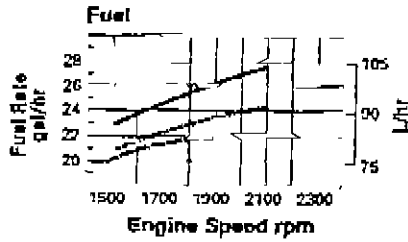
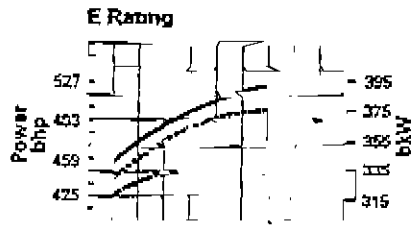

DITA, PA 5188
DITA, PA 2373
DITA, PA 2376

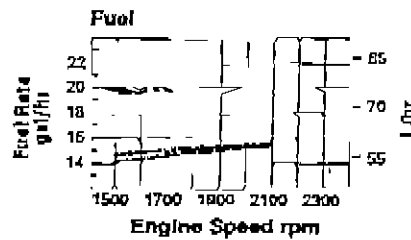
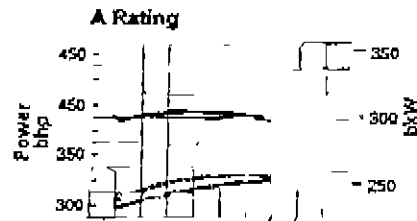
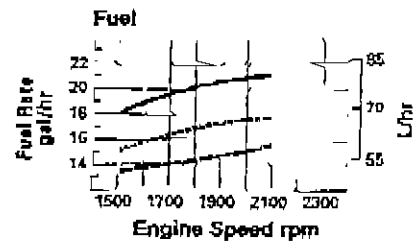
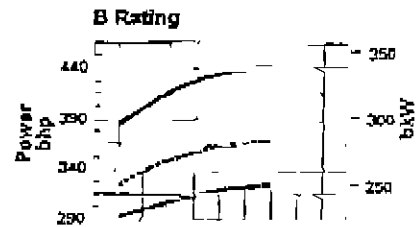
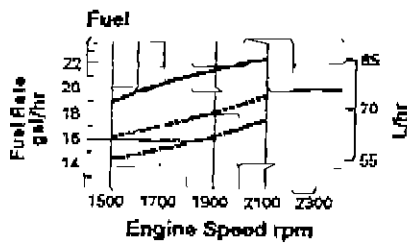
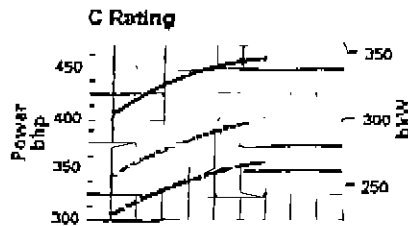

3406C INDUSTRIAL ENGINE**INDUSTRIAL RATINGS****IND-E**

IND-E ratings are for service where power is required for a short time for initial starting or sudden overload. For emergency service where standard power is unavailable. The maximum horsepower and speed capability of the engine can be utilized for a maximum of 15 uninterrupted minutes followed by one hour at intermittent or duration of the emergency. Operating limits are:

1. Time at full load not to exceed 5% of the duty cycle or 15 minutes max.
2. Load factor limited to 35%.
3. The maximum horsepower and speed capability of the engine can be utilized for a maximum of 15 minutes followed by one hour at intermittent or duration of the emergency.
4. Typical operating hours per year is 500.

Examples of an IND-E industrial application are:

1. Standby centrifugal water pumps
2. Oil field well servicing
3. Crash trucks
4. Gas turbine starters

IND-D

IND-D ratings are for service where rated power is required for period overloads. The maximum horsepower and speed capability of the engine can be utilized for a maximum of 30 uninterrupted minutes followed by one hour at intermittent. Operating limits are:

1. Time at full load not to exceed 10% of the duty cycle or 30 min max.
2. Load factor limited to 50%.
3. Full load operation to a maximum of 30 minutes followed by one hour at intermittent.
4. Typical operating hours per year is 1500.

Examples of an IND-D industrial application are:

1. Offshore cranes
2. Runway snowblowers
3. Water well drills
4. Portable air compressors
5. Fire pump certification power (advertised power)

IND-C (INTERMITTENT)

IND-C ratings are for service where power and/or speed are cyclic. The horsepower and speed of the engine which can be utilized for one uninterrupted hour followed by one hour of operation at or below the continuous rating.

Operating limits are:

1. Time at full load not to exceed 50% of the duty cycle or one hour max.
2. Load factor limited to 70%.
3. Full load operation limited to one uninterrupted hour followed by one hour of operation at or below the continuous rating
4. Typical operating hours per year is 3000 hours.

Examples of an IND-C industrial application are:

1. Agricultural tractors, harvesters, and combines
2. Truck - off highway
3. Fire pump application power (90% of certified power)
4. Blast hole drills
5. Rock crushers and wood chippers with high torque rise
6. Oil field hoisting

IND-B

IND-B ratings are for moderate-duty service where power and/or speed are cyclic.

Operating limits are:

1. Time at full load not to exceed 80% of the duty cycle.
2. Load factor limited to 85%.
3. Typical operating hours per year is 4000 hours.

Examples of an IND-B industrial application are:

1. Irrigation where normal pump demand is 85% of engine rating
2. Oil field mechanical pumping/drilling
3. Stationary/plant air compressors

IND-A (CONTINUOUS)

IND-A continuous ratings are for heavy-duty service when the engine is operated at rated load and speed up to 100% of the time without interruption or load cycling. Operating limits are:

1. No hour or load factor limitation.
2. Continuous operation at full load.
3. Average load factor to approach 100%.
4. Typical operating hours per year is over 4000 hrs.

Examples of an IND-A industrial application are:

1. Pipeline pumping
2. Ventilation
3. Customer specs

3406C INDUSTRIAL ENGINE



DIMENSIONS

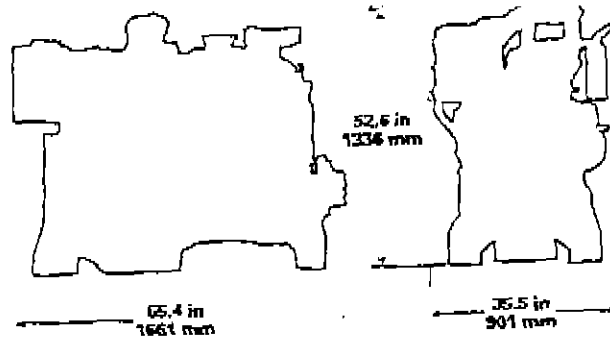

98022
8/9 File
CC FN
MFN
CFN
AW
REB

FAX

Date: Friday, September 20, 2002

Pages including cover sheet: 3

To: Amritendu Maji

From: GARY SARRAT JR
LOUISIANA MACHINERY P
2011 ENGINEERS RD
BELLE CHASSE
LA 70037

Phone

Fax Phone (504)885-0595

Phone

Fax Phone +1(504)391-0107

NOTE:

Maji,
Here is a little advance on the meeting at 10. See you then.
Thanks,
Gary Sarrat





Louisiana Machinery Power Systems



2011 Engineers Road
Belle Chasse, LA 70037
Phone 504-393-5050 FAX 504-391-0107

NY & Associates
D&O Construction
Handlin & Martin Consulting Engineers

9-19-02

Re Willowdale Pumping Station

In reference to the possible change in design conditions for the Willowdale Pumping Station, Louisiana Machinery Power Systems offers the following options and explanation.

When the question of design conditions was brought up by NY & Associates, they sought a solution that would offer 508HP in the same package dimensions and design. The 3406 originally quoted is rated at 345HP @ 1800rpm in a continuous duty application, as is generally accepted in this market. When the engines are to run they will be expected to operate continuously with a near constant load with little cycling. Caterpillar defines a "Continuous Duty" or "A Rating" as:

For heavy-duty service when an engine is operated at rated load and speed up to 100% of the time without interruption or load cycling. Time at full load is 100%. Typical application examples include pipeline pumping and ventilation.

This description clearly defines the accepted definition given the continuous pumping application, and is the specification offered in most cases. In order to meet this specification, 508 HP requires a change in engine model and design. The only way to maintain the designed dimensions of the 3406 is to change to the C-16 model. The C-16 is a 964 cubic inch compared to the 893 cubic inch 3406. The footprint and engine dimensions are similar, and no major changes would have to be made to the station design, with respect to the engine dimensions, save one. As an electronically controlled engine, the radiator would slightly increase in size to accommodate the separate charge air cooler in the dual core design. Of course, the only major design change would be the integration of a fully electronic engine into the original design of a mechanical engine's place. With respect to the engine only, there is an \$8-10,000 price increase.

Another option may include more clearly defining the actual duty cycle of the proposed units. This pumping station is designed to remove the excess rainwater from the Willowdale subdivision. The units will be run under full load for the duration of the flooding conditions. When removing minimal amounts of water, the engines will be under a lighter load, and run for a shorter period of time. The units will also be exercised under no load much of the time in between storms when the units will be called upon to pump large amounts of water. Caterpillar defines its "Standby" or "Intermittent E Rating" as such.

For service where rated power is required for a short time for initial starting or sudden overload. For emergency service where standard power is unavailable. Horsepower and speed capability of the engine can be utilized for a maximum of 15 uninterrupted minutes, followed by one hour at the Intermittent C rating, or for the duration of the emergency. Application examples include standby centrifugal water pumps, oil field well servicing, and gas turbine starters.

The typical duty cycle of these drainage pumps is more similar to the Standby rating defined above. The pumps will be used in emergency situations when normal drainage canals are not sufficient to move the water out of the area. The engine will run for the duration of the emergency at full load, until the water has been removed and conditions are normal. With expected exercising periods of 10-20 hours a month, and an estimated four weeks of 24-hour operation during flood periods, the resulting duty cycle totals under 900 hours a year usage. 200 hours of which is at high idle during monthly exercising. This duty cycle is more clearly defined by the "Standby - E Rating" defined above.

All of these duty ratings have been defined to more clearly estimate overhaul periods. The 3406 engine that operates in a truly continuous duty rating and application (15.5 gph) will reach its overhaul interval of 200,000 gallons of fuel consumed at 12,000 hours, or 16 months of around the clock running. These units, of course, will not be operated for 12,000 continuous hours around the clock. At the estimated 900 hours a year usage, the same 3406 at the "E Rating" (25gph) will reach its 200,000 gallons overhaul interval at 8,000 hours, or 9 years of usage in this application.

This same situation has arisen before on a job to build the Belle Chasse II station behind Bayou Barriere Golf Course. The design conditions changed and more horsepower was required. Now the station had been originally designed for a 3516 model which had a continuous rating of 1355 HP @ 1200RPM. After changing the gearing in the Philadelphia Right Angle Gear, the 1665 HP @ 1300RPM Intermittent rating was used because a switch to the 1600+ HP continuous duty rating would result in the use of a 3606 model (a 2500 extra cubic inches and over \$100K difference). It was decided that this application is more clearly defined by the Intermittent rating, and the change was made. The units have now been in operation for 9 years, and as of July have around 800 hours runtime. This usage schedules the engines for overhaul in 2012, or 20 years after installation. It is with respect to this type duty cycle that we feel the use of the "Intermittent E" or "Standby Rating" more clearly defines the actual duty cycle of these units, and should have no problems running at 525HP @ 2100RPM.

Should you have any questions or require any further information, please feel free to contact us.

Gary Sarrat Jr
Industrial Engine Sales
Louisiana Machinery Power Systems