

Ored.

2016-0281

**INTRODUCED BY: LARRY COCHRAN, PARISH PRESIDENT
(DEPARTMENT OF PUBLIC WORKS)**

ORDINANCE NO. 16-8-5

An ordinance approving and authorizing the execution of Change Order No. 1 (Balancing) for Parish Project No S091101 Primrose Lift Station and Force Main Upgrades to decrease the contract amount by \$5,605.00 and decrease the number of days by 74.

WHEREAS, Ordinance No. 15-11-27 adopted November 16, 2015 by the St. Charles Parish Council awarded construction of Parish Project No S091101 Primrose Lift Station and Force Main Upgrades to BLD Services, LLC; and,

WHEREAS, it is necessary to amend the contract to adjust the contract quantities with actual quantities resulting in a decrease to the contract amount by \$5,605.00 and decrease the number of days by 74.

THE ST. CHARLES PARISH COUNCIL HEREBY ORDAINS:

SECTION I. That Change Order No. 1 (Balancing) for Parish Project No S091101 Primrose Lift Station and Force Main Upgrades to decrease the contract amount by \$5,605.00 and decrease the number of days by 74 is hereby approved and accepted.

SECTION II. That the Parish President is hereby authorized to execute said Change Order No. 1 on behalf of St. Charles Parish.

SECTION III. St Charles Parish considers the project complete and hereby accepts all improvements.

The foregoing ordinance having been submitted to a vote, the vote thereon was as follows:

YEAS: BENEDETTO, HOGAN, WILSON, CLULEE, GIBBS, WOODRUFF, BELLOCK, FLETCHER, FISHER-PERRIER

NAYS: NONE

ABSENT: NONE

And the ordinance was declared adopted this 15th day of August, 2016, to become effective five (5) days after this publication in the official journal.

CHAIRMAN: Wendy Bennett

SECRETARY: [Signature]

DLVD/PARISH PRESIDENT: 8/16/16

APPROVED: [Signature] DISAPPROVED: _____

PARISH PRESIDENT: _____

RETD/SECRETARY: 8/17/16

AT: 3:35 p RECD BY: [Signature]

RECORDED IN 1506 BY CHARLES PARISH
CLERK OF COURT OFFICE

ON August 17, 2016

AS ENTRY NO. 417414

IN MORTGAGE/CONVEYANCE BOOK
NO. 1681 FOLIO 521

REFERENCE

OKD 15-11-27

SECTION 00806

CHANGE ORDER

No. 1 (Balancing)

DATE OF ISSUANCE: July 27, 2016

EFFECTIVE DATE: Date of Owner's Signature

OWNER St. Charles Parish

CONTRACTOR BLD Services, LLC

Contract _____

Project Primrose Lift Station and Force Main Upgrades

OWNER's Contract No. S091101

ENGINEER's Contract No. 1213

ENGINEER Environmental Engineering Services, Inc.

You are directed to make the following changes in the Contract Documents:

Description:

1. Delete the Following Work Items:

N/A

2. Add the Following Work Items:

- a. New Contract Item #X-1: Mister on the Odor Control System.
Addition of \$2,500.00 (L.S.). See attached cost estimate for details.
- b. New Contract Item #X-2: Poured concrete around the station.
Addition of \$2,250.00 (L.S.). See attached cost estimate for details.
- c. New Contract Item #X-3: Replace four (4) concrete panels.
Addition of \$9,995.00 (L.S.). See attached cost estimate for details.
- d. New Contract Item #X-4: Replace electrical pull box with larger box per Entergy.
Addition of \$6,765.00 (L.S.). See attached cost estimate for details.
- e. New Contract Item #X-5: Longer cord for flow meter.
Addition of \$575.00 (L.S.). See attached cost estimate for details.
- f. New Contract Item #X-6: Longer transducer cable.
Addition of \$1,575.00 (L.S.). See attached cost estimate for details.
- g. New Contract Item #X-7: Drain line along east side.
Addition of \$4,985.00 (L.S.). See attached cost estimate for details.
- h. New Contract Item #X-8: Replace drain line to conflict box.
Addition of \$5,250.00 (L.S.). See attached cost estimate for details.
- i. New Contract Item #X-9: Elevate control panel above BFE.
Addition of \$5,500.00 (L.S.). See attached cost estimate for details.

Total of Added Work Items = (+\$39,395.00)

3. Revise the Following Work Item Quantities:

- a. Contract Item #1A: 2" HDPE Electrical Conduit
The quantity is to be changed from 4,700 to 2,600 linear feet (-\$6,300.00).
- b. Contract Item #1B: 14" HDPE DR17 IPS Force Main
The quantity is to be changed from 1,900 to 1,824 linear feet (-\$2,280.00).
- c. Contract Item #1C: 12" Ductile CL53 Force Main
The quantity is to be changed from 20 to 18 linear feet (-\$340.00).

- d. Contract Item #45: Relocation of Infrastructure
The quantity is to be changed from 1 to 0 each (-\$35,000.00).
- e. Contract Item #1F: 4" HDPE DR11 IPS Force Main
The quantity is to be changed from 1,250 to 1,230 linear feet (-\$60.00).
- f. Contract Item #1G: 4" PVC DR18 Force Main
The quantity is to be changed from 80 to 75 linear feet (-\$300.00).
- g. Contract Item #11C: 4" HDPE Carrier Pipe (Directional Drill)
The quantity is to be changed from 1,250 to 1,230 linear feet (-\$720.00).

Total of Revised Work Items = (-\$45,000.00)

Reason for Change Order: List a reason for each Line Item listed above.

1. Deleted Work Items

N/A

2. Add Work Items

- a. A mister was requested on the Odor Control system by the Wastewater Department
- b. Concrete was needed around the station for maintenance and also for Entergy to access the transformer per the Wastewater Department's and Entergy's request.
- c. Four concrete street panels were replaced in order to have proper run off flow since installing the SFM per Wastewater Department.
- d. Replaced electrical box with a larger box per Entergy's requirements.
- e. The flow meter needed to be moved farther away to place it directly behind the entrance of the road barrier at the request of the Wastewater Department.
- f. The electrical control panel was moved atop the existing location of the old electrical control panel behind the shrubbery at the request of the Wastewater Department.
- g. A drain line was provided on the east side of the street to accommodate drainage problems in this area per Wastewater Department. All existing drainage pipes were originally not laid to proper grade for drainage. New line was required to properly drain this area.
- h. Drain line through the conflict box once the existing drain line was reconstructed to the proper alignment. Drain pipe was not originally in project. Original drain pipe was damaged (not by Contractor) prior to construction activities. Wastewater Department wanted to correct this drainage pipe problem before constructing new concrete surface above this drain pipe.
- i. The control panel had to be elevated one foot higher at the direction of the Public Works Engineer.

3. Revise Work Item Quantities

- a. Quantities adjusted to meet field construction.
- b. Quantities adjusted to meet field construction.
- c. Quantities adjusted to meet field construction.
- d. Item not required to complete project.
- e. Quantities adjusted to meet field construction.
- f. Quantities adjusted to meet field construction.
- g. Quantities adjusted to meet field construction.

Attachments: (List documents supporting change)

- 1. E-mail dated June 22, 2016 from Thomas Behan with BLD Services, LLC describing the change order.
- 2. E-mails between Thomas Behan with BLD Services, LLC and Chad Aucoin with Entergy discussing the pull box specifications for New Contract Item #X-4.

CHANGE IN CONTRACT PRICE:
Original Contract Price <u>\$979,700.00</u>
Net increase (decrease) from previous Change Orders No. <u> </u> to <u> </u> : \$ <u> 0.00</u>
Contract Price prior to this Change Order: <u>\$979,700.00</u>
Net decrease of this Change Order: -\$ <u>5,605.00</u>
Contract Price with all approved Change Orders: <u>\$974,095.00</u>

CHANGE IN CONTRACT TIMES:
Original Contract Times: Substantial Completion: <u> 235 </u> Ready for final payment: <u> 280 </u> (days or dates)
Net change from previous Change Orders No. <u> </u> to No. <u> </u> : Substantial Completion: <u> -0- </u> Ready for final payment: <u> -0- </u> (days)
Contract Times prior to this Change Order: Substantial Completion: <u> 235 </u> Ready for final payment: <u> 280 </u> (days or dates)
Net decrease this Change Order: Substantial Completion: <u> 74 </u> Ready for final payment: <u> 74 </u> (days)
Contract Times with all approved Change Orders: Substantial Completion: <u> 161 </u> Ready for final payment: <u> 206 </u> (days or dates)

RECOMMENDED: Environmental Engineering Services, Inc.

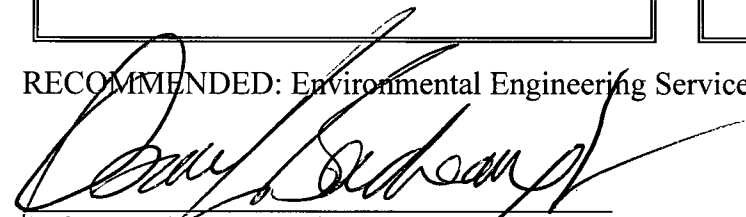
 ENGINEER (Oscar J. Boudreaux, Jr., P.E.)
 Date: 7/27/2016

APPROVED: St. Charles Parish

 OWNER (Larry Cochran, Parish President)
 Date: 8/17/16

APPROVED: BLD Services, LLC

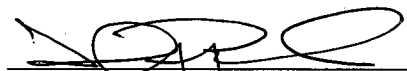
 CONTRACTOR (Thomas Behan)
 Date: 7/27/16

Heather Becnel

From: Oscar Boudreaux <oboudreaux@eesinc.net>
Sent: Friday, July 01, 2016 7:17 AM
To: hbecnel@eesinc.net
Subject: FW: Primrose Extras
Attachments: Primrose Extras CtC.pdf

Oscar J Boudreaux, Jr. P.E.
Environmental Engineering Svcs, Inc.
610 Belle Terre Blvd
Laplace, LA 70068
Office: 985-653-0185
Cell: 225-933-7280
Home: 225-819-1360

From: Thomas Behan [mailto:thomasb@bldllc.net]
Sent: Wednesday, June 22, 2016 3:20 PM
To: Oscar Boudreaux <oboudreaux@eesinc.net>
Cc: Lee Zeringue (lzingue@stcharlesgov.net) <lzingue@stcharlesgov.net>; L. J. Brady (ljbrady@stcharlesgov.net) <ljbrady@stcharlesgov.net>
Subject: Primrose Extras

Oscar,

See attached for the extras on Primrose.

- x-1 Requested a Mister on the Odor Control system
- x-2 Poured concrete around the station. This was needed for maintenance and also for Entergy to access the transformer
- x-3 Replaced 4 concrete street panels in order to have proper run off flow since installing the SFM
- x-4 Replace electrical box see email from Entergy
- x-5 Moved the flow meter farther away and moved the control panel
- x-6 Moved the control panel
- x-7 Drain line on east side of project
- x-8 Drain line thru conflict boxes
- x-9 Had to elevate the control panel more than the 1'.

Thomas A. Behan
BLD Services, LLC
2424 Tyler St.
Kenner, LA 70062
(504) 466-1344 office
(504) 602-1072 direct
(504) 461-5971 fax
(225) 303-8207 cell

St. Charles Parish CONTINUATION SHEET

BLD Services, LLC
 2424 Tyler St.
 Kenner, LA 70062

S0911011
 Cost to Complete

A	B	C	D	E	F	K	L	M
ITEM #	DESCRIPTION OF WORK	QTY	UNIT OF MEASUREMENT	UNIT PRICE	SCHEDULED VALUE	TOTAL QUANTITY (G + I)	TOTAL COMPLETED AND STORED TO DATE (H + J)	BALANCE TO FINISH (K - M)
38B	4" Transition Fitting (Harvey Adaptor)	2.00	EA	150.00	300.00	2.00	300.00	
X-1	Mister on Odor Control					1.00	2,500.00	
X-2	Pour Concrete around station					1.00	2,250.00	
X-3	Replace 4 conc panels					1.00	9,995.00	
X-4	Electrical Pull Box larger					1.00	6,765.00	
X-5	Longer Cord for Flow Meter					1.00	575.00	
X-6	Longer Transducer cable needed					1.00	1,575.00	
X-7	Drain line along east side					1.00	4,985.00	
X-8	Drain line thru conflict box					1.00	5,250.00	
X-9	Elevate control panel above BFE					1.00	5,500.00	

GRAND TOTALS	979,700.00	974,095.00	5,605.00
---------------------	-------------------	-------------------	-----------------

Heather Becnel

From: Oscar Boudreaux <oboudreaux@eesinc.net>
Sent: Friday, July 01, 2016 7:47 AM
To: hbecnel@eesinc.net
Subject: FW: Primrose Pull Box
Attachments: Primary pull box specs .PDF; Submittal 10 - Pull Box.pdf

From: Thomas Behan [mailto:thomasb@bldllc.net]
Sent: Wednesday, June 22, 2016 3:15 PM
To: Oscar Boudreaux <oboudreaux@eesinc.net>
Cc: Lee Zeringue (lzingue@stcharlesgov.net) <lzingue@stcharlesgov.net>; L. J. Brady (ljbrady@stcharlesgov.net) <ljbrady@stcharlesgov.net>
Subject: FW: Primrose Pull Box

See below and attached. This is going to be for X-4 in the extra spreadsheet

Thomas A. Behan
BLD Services, LLC

From: AUCOIN, CHAD J [mailto:CAUCOI3@entergy.com]
Sent: Wednesday, January 20, 2016 3:56 PM
To: Thomas Behan <thomasb@bldllc.net>
Subject: RE: Primrose Pull Box

Thomas,

The pull box specs are in the attached documents. For a three phase primary pull box it will have to be 48" X 96" in size. Any other questions let me know and I will do my best to answer.

Chad J. Aucoin
Engineer Associate
985-785-4317 Office
985-785-8071 Fax
caucoi3@entergy.com
Entergy Louisiana, LLC.
Distribution Mail Unit L-LUL-490
P.O. Box 61000
New Orleans, Louisiana
70161-1000

From: Thomas Behan [mailto:thomasb@bldllc.net]
Sent: Wednesday, January 20, 2016 3:47 PM
To: AUCOIN, CHAD J
Subject: RE: Primrose Pull Box

EXTERNAL SENDER. DO NOT click links if sender is unknown. DO NOT provide your user ID or password.

Chad,

Please see attached and advise if this box meets Entergy specs.

Thanks

Thomas Behan
BLD Services, LLC
(225) 303-8207
Sent from Outlook Mobile

On Thu, Dec 3, 2015 at 2:10 PM -0800, "AUCOIN, CHAD J" <CAUCOI3@entergy.com> wrote:

That is the correct size pull box. The standard continuous conduit that Entergy installs is SDR 13.5 HDPE.

*Chad J. Aucoin
Engineer Associate
985-785-4317 Office
985-785-8071 Fax
caucoi3@entergy.com
Entergy Louisiana, LLC.
Distribution Mail Unit L-LUL-490
P.O. Box 61000
New Orleans, Louisiana
70161-1000*

From: Thomas Behan [<mailto:thomasb@bldllc.net>]
Sent: Thursday, December 03, 2015 2:08 PM
To: AUCOIN, CHAD J
Subject: Primrose Pull Box

Chad,

See attached drawings. Please see on page 2 the size of the pull box. Is this the correct size of the pull box?

Also, can you send me conduit specs for the drilling the conduits?

Thomas A. Behan
BLD Services, LLC
2424 Tyler St.
Kenner, LA 70062
(504) 466-1344 office
(504) 602-1072 direct
(504) 461-5971 fax
(225) 303-8207 cell
thomasb@bldllc.net

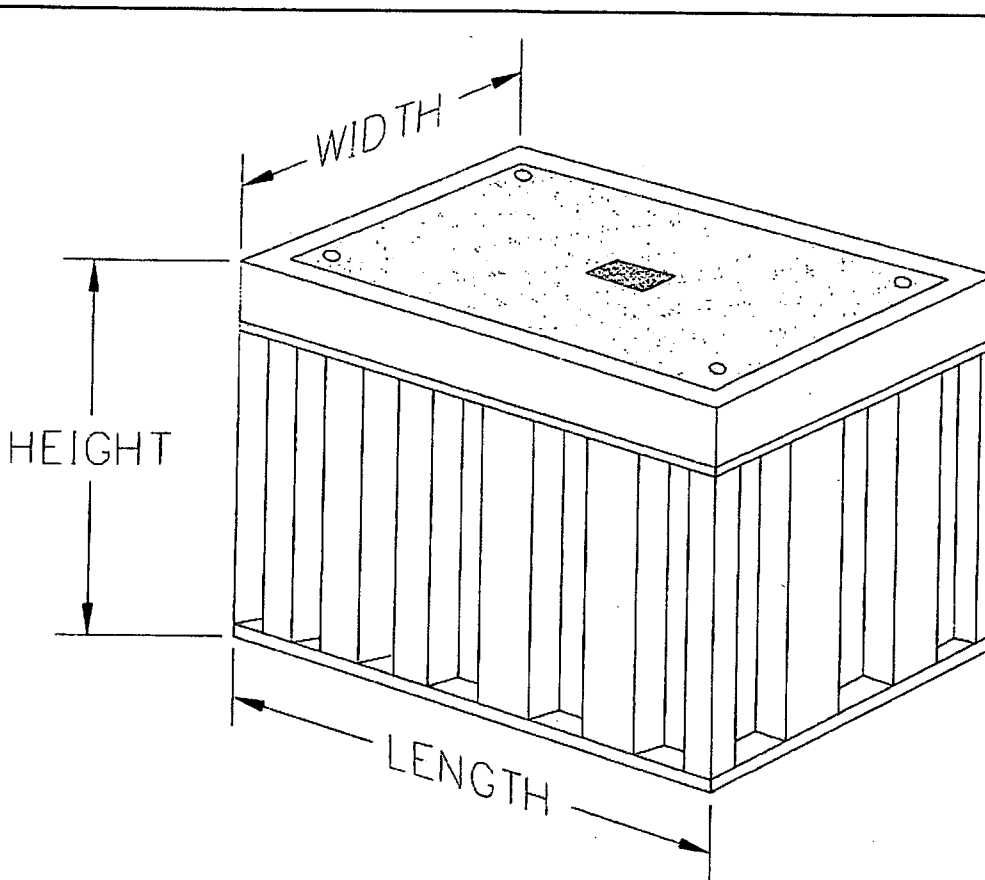

DISNAME	USC NUMBER	DESCRIPTION
PULLBOX-30X48	EN019155	PULL BOX, SINGLE PHASE, 30"W X 48"L X 30H FOR USE WITH FIBER OPTICS ONLY
PULLBOX-30X60	EN017578	PULL BOX, SINGLE PHASE, 30"W X 60"L X 48"H
PULLBOX-30X72	EN017579	PULL BOX, SINGLE PHASE, 30"W X 72"L X 48"H
PULLBOX-48X96	EN017580	PULL BOX, THREE PHASE, 48"W X 96"L X 48"H FOR USE WITH FEEDER CABLES ONLY.

NOTES:

1. ALL PULLBOXES ARE DESIGNED FOR A-16 LOADING (16,000 LBS. ON A 10" X 10" AREA)
2. ALL PULLBOXES ARE SUPPLIED WITH 2 PULLING EYES RATED AT 2000 LBS.
3. ALL PULLBOXES ARE SUPPLIED WITH TWO 30" LONG CABLE RACKS AND ADJUSTABLE 10" CABLE HOOKS
4. ALL PULLBOXES ARE SUPPLIED WITH A REMOVABLE BOTTOM.

ENTERGY SERVICES, INC.	
PULLBOXES	
APPROVED BY: JDS	DATE: 06-02-98
CHECKED BY: MCC	SCALE: N.T.S.
DRAWN BY: MCC	
 ENTERGY	No. UG1103011
	PLOT 1=1 SH 1 OF 1

NO. DATE:	REVISION	BY:	APPR:
-----------	----------	-----	-------