

STATE OF LOUISIANA

PARISH OF ST. CHARLES

RIGHT OF ENTRY AND RIGHT OF USE - SERVITUDE AGREEMENT

BE IT KNOWN, that on the dates hereinafter indicated but effective as of _____ (the “Effective Date”);

BEFORE the undersigned Notaries Public, each duly commissioned and qualified in and for the Parish of St. Charles, Louisiana, and in the presence of the hereinafter identified undersigned witnesses, personally came and appeared:

St. Charles Parish School Board (“The School Board”), through its duly authorized representative, Superintendent Felecia Gomez-Walker,

and

St. Charles Parish, a political subdivision of the State of Louisiana (“The Parish”), through its duly authorized representative,

_____ who declared that they hereby enter into this Right of Entry and Right of Use - Servitude Agreement (this “Agreement”), as follows:

RECITALS

Whereas, The School Board is the owner of certain real property in St. Charles Parish, Louisiana, bordering Schexnayder Lane in Destrehan, Louisiana, part of the Destrehan High School Campus facility as described herein by Exhibit “C” (“The Property”); and

Whereas, The Parish wishes, and does hereby agree, to construct and maintain a four (4') foot wide sidewalk on and across property owned by The School Board, running from Thomas Colby Drive, along the existing fence line adjacent to the Destrehan High School athletic stadium, passing the stadium itself and ending at the existing sidewalk gate entry, in the area designated in the attached Exhibit “A”, for purposes of improving means of ingress and egress to the Destrehan High School grounds (“The Sidewalk”); and

Whereas, The School Board and The Parish intend by this Agreement to establish a Right of Entry and Right of Use - Servitude Agreement, allowing The Parish to construct and maintain The Sidewalk, pursuant to Louisiana Civil Code Article 639, establishing their respective rights and obligations in connection with the construction and maintenance of The Sidewalk; and

NOW, THEREFORE, in consideration of the mutual promises contained herein and other valuable consideration, the receipt and sufficiency of which are hereby acknowledged, the parties hereto agree as follows:

I.

RIGHT OF ENTRY AND RIGHT OF USE - SERVITUDE

1.1. General Servitude for Ingress and Egress. The School Board does hereby establish, grant and create a nonexclusive right of entry and right of use to The Parish, for the purposes of ingress and egress, by pedestrian traffic and by such equipment as is necessary for the construction and maintenance of The Sidewalk, over, across and upon the Property. This Right of Entry and Right of Use shall be in favor of The Parish, its employees, contractors, deliverymen, agents, invitees, and licensees, as necessary to construct and maintain the sidewalk.

1.2. Reservation of Rights. Subject to any specific requirements or limitations set forth herein, The School Board hereby reserves its rights: (i) to pass over, across and upon the area designated by this Right of Entry and Right of Use, for the purpose of access to, and use of, its own property, including but not limited to that certain property on which The Sidewalk is situated; (ii) to use the surface of the area designated by this Right of Entry and Right of Use and the adjacent property for pedestrian traffic and to construct and place benches, lawn landscaping, utility and lighting poles and other like improvements, and for any other purposes which are not inconsistent with the Right of Entry and Right of Use granted herein; (iii) to exclusive use of the sub-surface of the area designated by this Right of Entry and Right of Use; and (iv) to grant to any other person, firm, corporation or other entity rights in, over, under and through such area designated by this Right of Entry and Right of Use; provided that none of the reservations set forth in clauses (i) through (iv) above shall individually or in the aggregate materially interfere with the Right of Entry and Right of Use granted to The Parish, as set forth herein.

1.3 Maintenance and Repair.

(a) Construction and Maintenance of The Sidewalk. The Parish shall construct, keep and maintain at all times The Sidewalk in good order, condition and state of repair, and shall inspect, maintain, repair and, as necessary, replace The Sidewalk, keeping it level, smooth and evenly paved with concrete in all respects suitable and safe for pedestrian foot traffic;

(b) No Charges for Use of The Sidewalk. No charge of any type shall be made to or collected from The Parish, its employees, contractors, deliverymen, agents, invitees, and licensees for the right to enter and to use all or any portion of The Sidewalk.

(c) Operation and Maintenance Expenses. The Parish shall bear the full and entire cost of performing its obligations set forth in Section 1.3(a) above in connection with The Sidewalk.

II.

GENERAL PROVISIONS

3.1 Notices. Any notice, request, demand, approval or consent given or required to be given pursuant to this Agreement shall be in writing and shall be: (i) mailed by United States certified mail, postage prepaid, return receipt requested; or (ii) delivered by recognized overnight courier; or (iii) delivered in hand, to the respective person at the address stated below or at the last changed address given by such respective

person to be notified as hereinafter specified. Any such notice shall be deemed to have been given on the date shown on the return receipt or delivery receipt if addressed as follows:

If to The School Board:

John Rome
Executive Director of Physical Plant Services
13855 River Road
Luling, LA 70070

If to The Parish:

V. J. St. Pierre

Parish President

PO Box 302

Hahnville, LA 70057

Copies of all notices required herein shall also be provided to the Superintendent of The St. Charles Parish Schools at the above address, and to the President of St. Charles Parish at the above address.

Either party to this Agreement may, at any time, change its address for the above purposes by mailing as aforesaid a notice stating the change and setting forth the new address.

3.2. Insurance and Indemnities.

(a) Insurance Requirements. Commencing with the effective date of this Agreement, The Parish, at its own sole expense, maintain or cause to be maintained comprehensive general public and automotive liability insurance against claims for personal injury or death and property damage occurring upon, in or about The Property, including but not limited to The Sidewalk, such insurance in each case to afford protection in accordance with the terms and limits specified on the attached Exhibit "B," naming The School Board as Certificate Holder and Additional Insured, and waiving subrogation in favor of The School Board. The Parish shall furnish to The School Board certificates evidencing the existence of such insurance required herein.

(b) Indemnity. The Parish shall indemnify, hold harmless and defend The School Board, its contractors, agents, and employees, from and against all claims, demands, suits, damages, costs, expenses and liabilities (including court costs and reasonable attorneys' fees) arising from or relating to

the death, accidental injury, loss or damage caused to any person or to the property of any person as shall occur by virtue of any exercise of any right afforded to The Parish by this Agreement, and/or by virtue of any acts or omissions related in any way to the construction and/or maintenance of The Sidewalk, except as to such death, injury, loss or damage as shall have been caused by the gross negligence or willful misconduct of The School Board, its contractors, agents or employees.

3.3. Miscellaneous.

(a) No Joint Venture or Partnership. Nothing contained in this Declaration shall be construed to make The School Board and The Parish partners or joint venturers, or to render either of said parties liable for the debts or obligations of the other, except as expressly provided in this Agreement.

(b) No Right of Transfer. The right of entry and right of use conveyed to The Parish by this Agreement is not transferable to any other person or entity without the express written consent of The School Board.

(c) Enforcement and/or Termination. In addition to any other rights it has pursuant to this Agreement, The School Board shall have the right to enforce the obligations and covenants of The Parish under this Agreement, or, at its exclusive option exercised within its sole discretion, to terminate this Agreement, if in its reasonable opinion, The Parish does not perform any of its obligations and/or covenants set forth herein.

(d) Recording. This Agreement shall be recorded in its entirety. The fees for such recording shall be borne by The School Board.

(e) Captions. The captions and headings herein are for convenience and reference only, and in no way define or limit the scope and content of this Agreement or in any way affect its provisions.

(f) Laws of Louisiana and Partial Invalidity. This Agreement shall be governed by and construed in accordance with the laws of the State of Louisiana. If any provision or portion of this Agreement, or the application thereof to any person or circumstances shall, to any extent, be determined invalid, unenforceable, or illegal by a court of law, the remainder of this agreement shall be valid and enforceable to the fullest extent permitted by law.

(g) Counterparts. This Agreement may be executed in several counterparts, each of which shall be deemed an original, and all of such together shall constitute one and the same instrument.

(h) Gender and Number. All terms contained herein shall be construed, whenever the context of this Agreement so requires, so that the singular number shall include the plural, and the plural the singular, and the use of any gender shall include all genders.

3.4 Termination. The School Board may, at its option, terminate this Agreement, upon thirty (30) days written notice to The Parish, if The School Board determines, in its sole discretion that it requires The Property for another purpose which is incompatible with its continued use as The Sidewalk. In the event of the exercise of such termination, all obligations of The Parish under This Agreement shall cease immediately, and any removal of concrete/paving for The Sidewalk will be at the expense and direction of The School Board.

THUS DONE AND SIGNED by The St. Charles Parish School Board, through its duly authorized representative, Superintendent Felecia Gomez-Walker, on _____ [date] in St. Charles Parish, Louisiana, before me, _____, the undersigned Notary Public, duly commissioned and qualified in and for said parish and state, and in the presence of the undersigned competent witnesses, who have signed with Ms. Gomez-Walker and me, after a due reading of the whole.

THE ST. CHARLES PARISH SCHOOL BOARD

by:

Felecia Gomez-Walker
Superintendent

WITNESSES

NOTARY PUBLIC

Print Name: _____

My commission expires: _____

THUS DONE AND SIGNED by St. Charles Parish, through its duly authorized representative, _____, on _____[date] in St. Charles Parish, Louisiana, before me, _____, the undersigned Notary Public, duly commissioned and qualified in and for said parish/county and state, and in the presence of the undersigned competent witnesses, who have signed with _____ and me, after a due reading of the whole.

ST. CHARLES PARISH

by:

V.J. St.Pierre
President

WITNESSES:

NOTARY PUBLIC

Print Name:_____

My commission expires:_____



ST. CHARLES PARISH

DEPARTMENT OF PUBLIC WORKS/WASTEWATER

100 RIVER OAKS DRIVE • DESTREHAN, LOUISIANA 70047

(985) 783-5102 • (985) 783-5104 • FAX (985) 725-2250

Website: www.stcharlesparish-la.gov

V.J. ST. PIERRE, JR.
PARISH PRESIDENT

SAM SCHOLLE
DIRECTOR

Mr. John Rome
Executive Director of Physical Plant Services
St. Charles Parish School System

Mr. Rome,

Please see our intentions in building a sidewalk along Schexnayder Lane in Destrehan. First we will need a property servitude/ right of entry agreement from the School Board giving Public Works access to the property along the fence line and the side of the Stadium. We will construct a 4 foot wide sidewalk from Thomas Colby Dr. and then follow the existing School Board fence line going south passing up the stadium and stopping at the existing sidewalk gate entry. The gate at this location will be modified to accommodate the student's entry and exiting at the cost of the school system. Public Works will begin getting pricing from private contractors after the above mentioned agreement is in place. We will need approximately three weeks to select a contractor and then another three weeks for the construction and completion of the sidewalk (Weather Permitting).

Please help in producing the servitude/ right of entry agreement between St Charles Parish Public Works and the St. Charles Parish School System.

Thank You,

Stephen R. Truitt

General Superintendent

Public Works / Contract Monitor

Office # 985-783-5102

Cell # 504-559-3652

c.c. Mr. Andy Mire Project Manager of Physical Plant Services
St. Charles Parish School System

Exhibit "C"

PROPERTY DESCRIPTION
SERVITUDE FOR
PROPOSED SIDEWALK

A certain tract of land situated in the Parish of St. Charles, State of Louisiana, on the East Bank of the Mississippi River, located in Sections 11 & 12, Township 12 South, Range 8 East, and being more particularly described as follows:

From the intersection of the southwesterly right of way of Thomas Coby Drive and the southeasterly right of way of Schexnaydre Lane, proceed S47°27'09"W along the southeasterly right of way of Schexnaydre Lane a distance of 252.15 feet to the POINT OF BEGINNING, thence S22°33'38"W a distance of 47.28 feet, thence S47°35'51"W a distance of 245.11 feet, thence S67°53'32"W a distance of 29.89 feet, thence S47°14'05"W a distance of 116.28 feet, thence S47°54'55"W along edge of existing concrete, a distance of 76.37 feet, thence N44°40'33"W along an existing fence a distance of 8.68 feet to the right of way of Schexnaydre Lane, thence N47°27'09"E along said right of way a distance of 508.97 feet to the point of beginning, containing 7,363.95 square feet all in accordance with a plan by Lucien C. Gassen, PLS, dated July 23, 2015.



Lucien C. Gassen, PLS

Registration No. 353



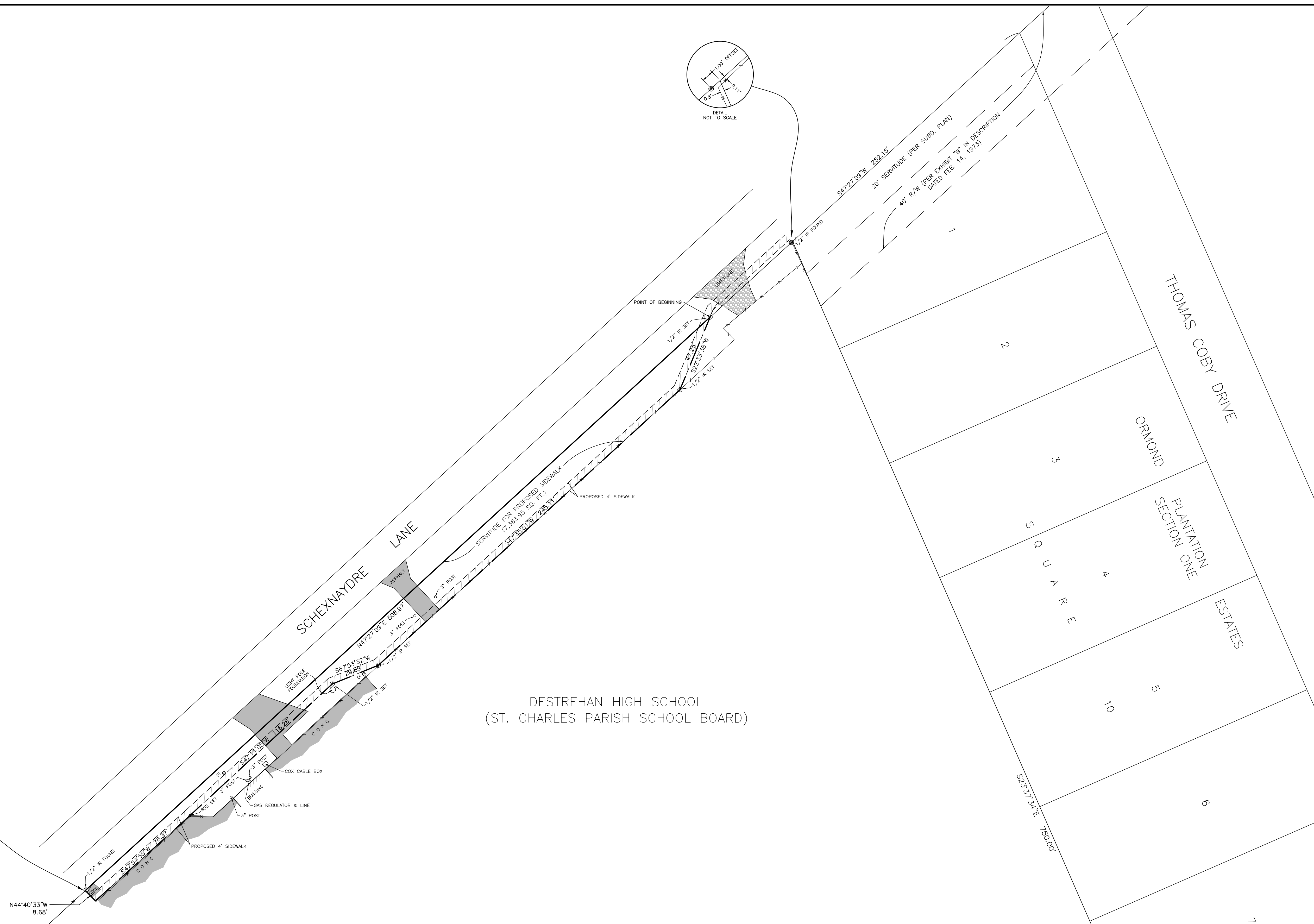
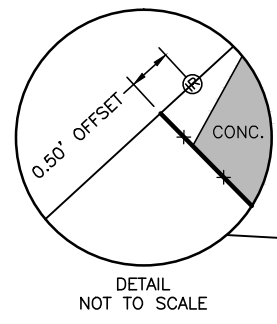
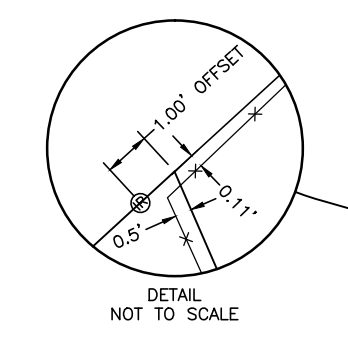

SERVITUDE FOR PROPOSED SIDEWALK
ON PORTION OF
ST. CHARLES PARISH SCHOOL BOARD PROPERTY
AT DESTREHAN HIGH SCHOOL
IN SECTIONS 11 & 12, T12S - R8E
ST. CHARLES PARISH, LOUISIANA
SCALE: 1" = 30' JULY 23, 2015

LEGEND
DI = DRIP INLET
-X- FENCE
BEARINGS ARE BASED
ON REFERENCE PLAN

REFERENCE PLAN:
DESTREHAN HIGH SCHOOL BY LUCIEN C. GASSEN,
DATED AUGUST 2, 2007

THIS IS NOT A PROPERTY
BOUNDARY SURVEY.

LUCIEN C. GASSEN, PLS
Registration No. 353
(985) 785-0745
1028 Gassen Street
Luling, Louisiana 70070